



**Test Suite for the  
CAx Interoperability Forum  
Round 48J**

March – September 2021

***Release 1.1***

6 July 2021

**Contacts**

Jochen Boy  
PROSTEP AG  
[jochen.boy@prostep.com](mailto:jochen.boy@prostep.com)

Robert Lipman  
NIST  
[robert.lipman@nist.gov](mailto:robert.lipman@nist.gov)

Phil Rosché  
ACCR, LLC.  
[phil.rosche@accr-llc.com](mailto:phil.rosche@accr-llc.com)

## Table of Contents

<b>1</b>	<b>Introduction.....</b>	<b>3</b>
1.1	Functionality tested in this round .....	4
1.2	General testing instructions for this round.....	4
1.3	Testing Schedule.....	5
1.4	Copyrights on Test Cases .....	5
<b>2</b>	<b>Synthetic Test Case Specifications .....</b>	<b>6</b>
2.1	Test Case PMI: Semantic PMI Representation & Graphic PMI Presentation .....	6
2.2	Test Case KM2: Kinematics.....	11
2.3	Test Case UD4: User Defined Parameters .....	15
2.4	Test Case AS3: AP242 Edition 2 Minor Revision Domain Model XML.....	18
2.5	Test Case CO2: Composite Materials (Ply Contour).....	21
2.6	Test Case CO4: Composite Parts with Multiple Rosette .....	24
2.7	Test Case PID: Persistent IDs .....	27
<b>Annex A</b>	<b>NIST Model Translation Configuration Considerations .....</b>	<b>33</b>
<b>Annex B</b>	<b>NIST Model Definitions.....</b>	<b>35</b>

## List of Figures

Figure 1:	CAx-IF Round48J Schedule .....	5
Figure 2:	Illustration of the KM2 test model with indicated kinematic pairs.....	12
Figure 3:	Overview on User-Defined Parameters and Properties defined in the test model ..	16
Figure 4:	Illustration of the Torque Converter model.....	19
Figure 5:	Torque Converter structure and indication if included attributes.....	20
Figure 6:	Illustration of the CO2 Test Case.....	22
Figure 7:	Illustration of the CO4 Test Case and Laminate Table.....	25
Figure 8:	NIST FTC09, View C, slotted hole .....	30
Figure 9:	NIST Test Case FTC09, View A, Detail of Hole .....	30
Figure 10:	NIST Test Case FTC09, View C, Detail of Slotted Hole .....	31
Figure 11:	NX 8 vs. NX 9 Dimension Display Names .....	34

## Document History

Release	Date	Change
1.0	2021-06-11	Initial Release
1.1	2021-07-06	Updated definition for CO4

## 1 Introduction

The CAx Interoperability Forum (CAx-IF) is part of the Model-Based Interoperability Forum (MBx-IF), which is a joint effort between AFNeT, PDES, Inc. and prostep ivip. An interoperability forum is a logical collection of a user group and an implementer group, focused on specific capabilities of a named standard, in this case ISO 10303 STEP.

- The **User Group** is comprised of industry representatives, all members of at least one of the Interoperability Forum hosting organizations. The group will define and prioritize use cases, derive requirements and related validation properties as well as document user best practices.
- The **Implementor Group** is a group of software vendors, 3<sup>rd</sup> party integrators, and independent implementors, all members of at least one of the Interoperability Forum hosting organizations, that define recommended practices based on the prioritized use cases provided by the user group and validate them in test rounds.

The objectives of the CAx-IF concentrate primarily on testing the interoperability and compliance of STEP processors based on AP242 Ed. 1 & 2 and include documenting and prioritizing use cases, requirements and best practices to ensure completeness and consistency of the STEP standard and its implementations, implementing new functionalities based on users' requirements while ensuring these do not adversely affect existing implementations, avoiding roadblocks by establishing agreed-upon approaches, and increasing user confidence in STEP by providing interoperable commercial software products.

The CAx-IF's Implementor Group performs two test rounds per year for each domain and presents summary results to the user community. Furthermore, Recommended Practices are developed, and issues are reported to the standards development community.

The test rounds in general combine testing of synthetic and production models. Production models will in most cases be provided by the user companies of the organizations AFNeT, PDES, Inc., and prostep ivip Association. When production models are not available from the user companies, "production-like" models will be solicited from the various CAx-IF participants.

This test suite includes synthetic models for testing the following capabilities: Product Manufacturing Information (PMI), both as Graphic Presentation and as Semantic Representation, 3D Tessellated Geometry, Kinematics, and Assembly Structure with External References in AP242 BO Model XML format.

## 1.1 *Functionality tested in this round*

Functionality tested in this round relates to:

- **Product Manufacturing Information (PMI)** describes the capability to embed information about dimensions, tolerances and other parameters which are necessary input for the manufacturing and measuring of the part from the 3D model. This round, the focus will be on the two approaches for the transfer of PMI in the 3D model:
  - “Tessellated Presentation” refers to breaking down each annotation into tessellated elements as supported by AP242 and exchanging them as geometry. This preserves the exact shape of the annotation but is human readable only. The test will include section views as well.
  - “Semantic Representation” refers to the intelligent transfer of PMI data in an associative and reusable way. This scenario aims towards driving downstream usage and later modifications of the model. The data is machine-readable, but not necessarily visible in the 3D model. The test also includes additional presentation data, which can be linked to the corresponding PMI representation.
- **AP242 BO Model XML** is an implementation format introduced with AP242, and the designated process format for many applications in the aerospace and automotive industries. It will be used in combination with geometry formats matching the respective requirement. In the CAX-IF, the geometry files will be in STEP Part 21 format. The XML files contain the assembly structure and part master information. The tests, which are conducted jointly with the PDM-IF, primarily aim at improving CAX-PDM interoperability by ensuring that the different types of systems correctly cope with the different levels of information.
- **Composite Materials** are made by layering various plies of material on top of each other. They can be defined in an implicit-precise way, by giving the laminate tables, ply boundaries, orientation, materials, and laminated cores; or in an explicit-tessellated way by calculating the resulting 3D Tessellated Solid. Both representations can be linked to each other.
- **Kinematics** is a capability in AP242 that allows describing the motion of parts over time and in relation to each other. This includes the definition of mechanisms with joints and constraints, defining the kinematic relationships between the parts, as well as motions, which are defined by capturing the positions of the moving parts at discrete points in time. In order to cover Aerospace as well as Automotive use cases, and to increase the range of participating systems, this capability is being tested jointly with the JT-IF.
- **Persistent Entity IDs** enable the ability to track a product’s model information during design iteration, and from design iteration through to manufacturing and quality analysis. This will allow downstream systems to update their representations of the design model and update their manufacturing and metrology planning to reflect changes in the design.
- **User Defined Parameters** at the part level as well as at the geometry level are used to convey data that drives certain aspects of a model, e.g., geometric features, or engineering notes and requirements that manufacturing has to comply with. This may also include custom-defined properties. A target application shall be able to pick up on these and make appropriate decisions for downstream processes.

## 1.2 *General testing instructions for this round*

The general procedures for communication of models and statistics are outlined in a separate document, entitled ‘General Testing Instructions’. The document can be retrieved from the CAX Interoperability Forum web sites. The latest version is v1.13, dated September 29, 2017.

### 1.3 Testing Schedule

The following schedule has been agreed upon for Round 48J:

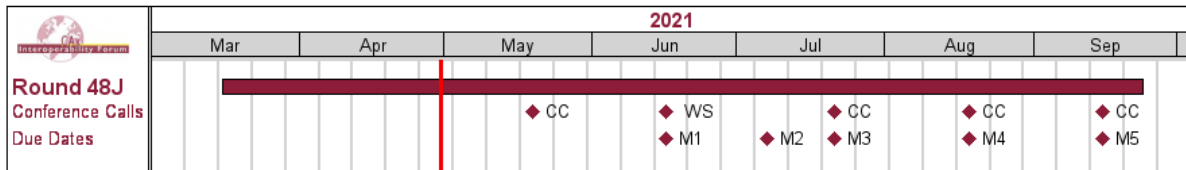

M1: Test Suite and Rec.Pracs. available - M2: Initial STEP files and native stats due  
 M3: Initial release of files for testing - M4: Initial target stats due - M5: Preliminary results available

Date	Action
19 May 2021 (Wed)	Round 47J Follow-up / Round 48J Preparation Call
16 Jun 2021 (Wed)	Test Suite and Rec.Pracs. available / CAX-IF Round 48J Kick-Off Meeting in Cyberspace
7 Jul 2021 (Wed)	Initial STEP files and native stats due
21 Jul 2021 (Wed)	Initial release of files for testing / 1st CAX-IF Round 48J Conference Call
18 Aug 2021 (Wed)	Initial target stats due / 2nd CAX-IF Round 48J Conference Call
15 Sep 2021 (Wed)	Preliminary results available / 3rd CAX-IF Round 48J Conference Call
21 Sep 2021 (Tue) - 23 Sep 2021 (Thu)	CAX-IF Round 48J Review Meeting in Cyberspace

Figure 1: CAX-IF Round48J Schedule

As it seems unrealistic that all travel restrictions imposed in the context of COVID-19 will be lifted in time to ensure a well-attended meeting in September, this event will once again be held fully online.

### 1.4 Copyrights on Test Cases

#### 1.4.1 CAX-IF

None of the production test cases which were provided by the AFNeT, PDES, Inc. and prostep ivip member companies may be publicly released for any purpose. The test cases can be freely distributed among the CAX-IF members and can be used for any purposes that are related to CAX-IF testing (i.e. testing, documentation of testing efforts, etc.), if a reference to the originating company is made.

The test cases must not be used for any purposes other than CAX-IF testing or outside of AFNeT, PDES, Inc. and prostep ivip. Test cases provided by the LOTAR project for testing of specific capabilities are applicable to the same restrictions and may not be used outside LOTAR or the CAX-IF.

#### 1.4.2 NIST

The test cases developed at the National Institute of Standards and Technology (NIST) are not subject to copyright protection and are in the public domain. NIST assumes no responsibility for the components of the test system for use by other parties and makes no guarantees, expressed or implied, about their quality, reliability, or any other characteristic. The use of the CAD systems to create the Test Models does not imply a recommendation or endorsement by NIST.

For more details, read the disclaimer at <http://go.usa.gov/mGVm>

## 2 Synthetic Test Case Specifications

### 2.1 Test Case PMI: Semantic PMI Representation & Graphic PMI Presentation

All information about this test case can also be viewed in CAESAR on its Information page.

#### 2.1.1 Motivation

Product Manufacturing Information (PMI) is required for numerous business use cases in the context of STEP data exchange. Among others, it is a prerequisite for long-term data archiving. In addition, PMI can be used to drive downstream applications such as coordinate measuring and manufacturing.

Semantic PMI Representation relates to the capability to store PMI data in the STEP file in a computer-interpretable way, so that it can be used for model redesign or downstream applications. Though the definition of the data is complete, it is by itself not visible in the 3D model.

In addition to use cases that require a fully defined, precise, semantic definition of the part geometry and associated PMI, there are also scenarios where the presentation of the data – geometric elements and annotations – for visual consumption are the primary goal. In such cases, a simplified and optimized version of the model is sufficient. The tessellated geometry model included in AP242 provides an efficient mechanism to support this.

A wide variety of test models is available from NIST as well as prostep ivip, each containing a different selection of PMI elements. Each model typically concentrated on particular subsets of PMI data.

#### 2.1.2 Approach

The approach to be used is described in the latest version (at least v4.0.8, dated 4 September 2020) of the “Recommended Practices for Representation and Presentation of PMI (AP242)”, which can be found in the CAX-IF member area under “Information on Round46J of Testing”.

Within the PMI domain, the following functionalities are in scope of Round 48J:

- Semantic PMI Representation
- Tessellated PMI Presentation
- Correct implementation and definition of the Saved Views (view layout and contents)
- Linking of PMI Representation to Presentation
- Transfer of editable PMI text as User Defined Attributes
- PMI Validation Properties (Representation & Presentation)

The AP242 schema to be used is the AP242 Edition 2 IS schema, which is available on the CAX-IF homepages under “Public Testing Information”. Note that this is the same schema that was previously stored in the member area as AP242 Ed. 2 DIS schema; there have been no changes for the final publication.

**Note:** The final longform EXPRESS schema for AP242 Ed.2 Minor Revision comes with SMRL v9 before July 19.

**Pre-checking of files with SFA:** All vendors generating STEP files for the SP7 test case shall run them through the latest version of NIST’s STEP File Analyzer and Viewer (SFA; currently version 4.52). The tool provides feedback on basic syntax errors such as missing or malformed entity instances. Files with such errors will not be accepted for testing.

SFA can be downloaded for free at <https://go.usa.gov/yccx/>

### 2.1.3 Testing Instructions

The tests will be performed based on a verified set of test models, each with set of well-defined PMI elements. In Round 48J, the models developed in the context of the “MBE PMI Validation and Conformance Testing” project will be used again, as they have been designed with emphasis on particular PMI capabilities.

#### 2.1.3.1 NIST Test Model Overview

The NIST models are constantly updated to the latest CAD software releases by the respective system vendors, in order to improve the definition of the models using the latest CAD system capabilities.

The links to the test model definitions, the NIST web page for the MBE PMI Validation and Conformance Testing Project, and illustrations of the 11 test cases can be found at the end of this document in Annex B.

#### 2.1.3.2 NIST Test Model Access

The updated native CAD files can be downloaded using the hyperlinks in the list below:

- [CATIA V5-6R2019](#)
- [Creo 4](#)
- [NX12](#)
- [Inventor 2021](#)

Even though many updates have already been made by the respective system vendors, a number of verification issues remain to be solved. Should new native models with further updates become available during the test round, they will be distributed and announced accordingly.

#### 2.1.3.3 NIST Test Model Selection

A subset of the NIST test cases has been selected for Round 48J:

- **FTC-6:** Datum targets (lines and curves), radius, more holes
- **FTC-7:** PMI validation properties, dimensions, position tolerances and surface profile tolerances
- **FTC-8:** Complex and stacked feature control frames, mix of tolerances and modifiers
- **FTC-9:** Perpendicularity on hole diameter (every vendor had a different solution)
- **FTC-10:** Datum features and Datum targets; mix of tolerances and modifiers

**Note** that these are the same test cases as in Round 47J. To help with prioritization, a list with long-standing issues has been provided by Bob Lipman, and is available as “R48J\_PMI\_Issues.pdf” in the CAX-IF member area under “Information on Round 48J of Testing”.

**Note** that to keep the workload within reasonable bounds, PMI validation properties will be formally evaluated only on FTC-7.

**Note** that vendors are encouraged to submit STEP files for all 11 NIST test cases, for investigation by Bob Lipman. However, only STEP files for the five models listed above will be distributed for testing in Round 48J and their respective results evaluated on CAESAR.

## 2.1.4 Test Model Configuration

The following functionality shall be included in the test files provided for this round of testing, as far as it has been implemented by the CAX-IF participants and is described in the Recommended Practices:

- PMI Representation – the re-usable representation of PMI data should be included in all PMI models to the extent supported by the native system.
- PMI Tessellated Presentation – Many CAD systems require some minimal presentation information to be able to handle the PMI data in a model. Usually, both PMI representation and presentation data are included in the same file. Thus, some form of presentation information shall be included in the PMI test case as well.
- Definition of “Saved Views” – as far as supported, include the saved views defined in the models, which contain a subset of annotations in the file, and provide a pre-defined position of the model in the design space.
  - All models have multiple Saved Views defined. In the test case definition documents, each page of the PDF document represents one Saved View.
  - For each view, a screenshot showing the model layout (displayed elements, orientation, zoom) shall be provided.

**Note** that it is possible to attach several screenshots to one set of statistics in CAESAR. The name of the view shall be given as description for the screenshot.
  - Both “basic” and “advanced” view implementations are allowed.
  - The Saved Views shall also correctly show (or hide) the part geometry, as well as the non-solid Supplemental Geometry contained in some of the models (see section 9.4.2 / Figure 93 in the PMI Rec. Practices v4.0.8. An additional document pointing out important supplemental geometry elements for the NIST test cases is available in the CAX-IF member area, under “Information on Round 42J of testing”).
- Editable PMI Text – Some information relevant for PMI is not encoded in semantic entities, but given as plain text, such as the title block information or additional text on feature control frames. In the context of semantic data exchange, this content needs to be editable in the target system. The approach to be used for this is based on the transfer of User Defined Attributes, and its application in the context of PMI is described in section 7.4 of the PMI Recommended Practices v4.0.8.
- Linking PMI Representation to Presentation – If a model contains PMI Representation information as well as Presentation data, the corresponding elements shall be linked together, so that a Representation element “knows” which annotation it is being presented in the model. The approach to create this link is described in section 7.3 of the PMI Rec. Pracs. (v4.0.8).
- Cross-highlighting of annotations and annotated shape – if supported, include in the STEP file the information necessary to maintain the association between graphic annotations and the annotated shape elements in a way, that after import, when highlighting an annotation, the shape elements annotated by it are highlighted too, and vice versa.
- Validation Properties – All participants providing STEP files for this test case are encouraged to include validation properties for PMI semantic representation and graphic presentation, as defined in the PMI Recommended Practices v4.0.8, sections 10.1 and 10.2 respectively.
  - **Note** that in Round 48J, PMI validation properties will be formally evaluated only on the FTC-7 test case.

Also refer to Annex A for test model translation configuration considerations.



## 2.1.5 Statistics

For each STEP file exported or imported for the PMI test case, vendors must submit the corresponding statistics. To do so, go to the [ PMI Data Sheet ], and either fill in the web form, or upload a comma-delimited file (.csv) with the data as listed below.

### Native Statistics

When exporting a STEP file, report what data importing systems should expect to find. For numeric statistics, enter the respective value or 'na' if not supported. For other statistics, select either 'full support' (i.e. test case and Rec. Pracs. definitions are fulfilled), 'limited support' (meaning the implementation does not meet all criteria and issues may be expected on import), or 'na' if not supported.

### Target Statistics

When importing a STEP file, report the results after processing the file as described below.

### Screenshots

For each Saved View in the model, provide one screenshot, which illustrates the layout (displayed geometry and annotation, model orientation, and zoom factor). Give the name of the view as the description of the screenshot. Note that CASEAR allows the addition of multiple screenshots per dataset.

**Note** that in order to count the GD&T elements for the statistics, per agreement during the R22J Review Meeting, the actual STEP entity types (`datum`, `datum_target`...) shall be considered.

**Note** that based on the Round 35J results, a new count has been added for Composite Tolerances as defined in section 6.9.9. of the PMI Rec. Pracs. (v4.0.8).

**Note** that all statistics – native and target – shall be based on the Semantic PMI Representation data only, and not take any presentation into account.

**Note** that for evaluation, the spreadsheets generated by the STEP File Analyzer and Viewer will be amended with corresponding aggregations of relevant counts and charts.

## Data Sheet Columns

column name	description
<b>model</b>	The name of the test model, here 'pmi', with one of the following suffixed: 06, 07, 08, 09, 10.
<b>system_n</b>	The system code of the CAD system creating the STEP file
<b>system_t</b>	The system code of the CAD system importing the STEP file. For native stats, select 'stp'
<b>scope</b>	A short designation for the contents of the model as defined in the Test Suite. This is for information only; there will be no results for this field.
<b>dimensions</b>	The number of dimensions processed
<b>datums</b>	The number of datums processed
<b>datum_targets</b>	The number of datum targets processed
<b>tolerances</b>	The number of tolerances (all types combined) processed, regardless of composition.
<b>compos_tols</b>	The number of composite tolerances processed (number of instances of geometric_tolerance_relationship per section 6.9.9. in the PMI Rec. Pracs. v4.0.8).
<b>labels</b>	The number of labels processed
<b>pmi_semantic_txt</b>	all/partial/none – whether 'semantic' (editable) PMI text was transferred correctly (content and associativity)
<b>pmi_semantic_val-prop</b>	all/partial/none – whether the validation properties for Semantic PMI Representation matched for all, some or none of the semantic PMI elements.
<b>saved_view</b>	The name of the Saved View which is the basis for the view-related statistics
<b>view_annot</b>	The number of annotations included in the specified saved view.
<b>view_pos</b>	pass/fail, whether the model orientation and zoom factor stored for the Saved View could be restored successfully.
<b>elem_visibility</b>	all/partial/none – whether all, some, or none of the elements to be displayed in the indicated saved view were mapped correctly into the corresponding draughting_model.
<b>highlight</b>	all/partial/none – whether the cross-highlighting for annotations and annotated shape elements works correctly
<b>pmi_graphic_pres</b>	all/partial/none – whether the graphic PMI annotations included in the file could be processed correctly
<b>pmi_present_val-prop</b>	all/partial/none – whether the validation properties for Graphic PMI Presentation matched for all, some or none of the presentation elements.
<b>pmi_linked_pres_rep</b>	all/partial/none – whether the Semantic PMI Representation elements and (Graphic) PMI Presentation elements were linked correctly together.
<b>date</b>	The date when the statistics were last updated (will be filled in automatically)
<b>issues</b>	A short statement on issues with the file

## 2.2 Test Case KM2: Kinematics

All information about this test case can also be viewed in CAESAR on its Information page.

### 2.2.1 Motivation

CAD methods have been used for many years now to design individual parts and assemblies of all sizes across all industries, from a single rivet to an entire airplane. Classically, the main focus is to ensure that the part can be manufactured correctly.

Products such as cars, planes or assembly lines are not static, however, contain many moving components: engine, power windows, foldable roof, windshield wipers, cargo doors, etc. Thus, Kinematics are used to ensure they move correctly, as well as to illustrate the behavior of the finished product. The use cases range from the definition of the Kinematic Mechanism, providing all relationships and constraints between the elements so that their definition can be changed in the receiving application, to Kinematic Motion, which works like a movie by providing discrete positions of the components over time.

The goal is to use a neutral standard format – AP242 BO Model XML – for the definition of the Kinematic mechanisms and motion, with external references to the applicable geometry format for the respective use case.

### 2.2.2 Approach

The approaches for “Kinematic Mechanism” and “Kinematic Motion” are described in the “Recommended Practices for STEP AP242 TC Business Object Model XML Kinematics”, Version 0.12 (dated 4 June 2020), which can be found in the CAD member area of the CAX-IF web sites under “Information on Round 47J of Testing”.

During the development of these capabilities, several new entity types have been defined to improve the implementation structure. This will be included in AP242 with the DIS release of Edition 2. To enable immediate testing, a trial XSD schema is available, which is built by extending the AP242 TC schema with these new entities. It is available at the following URL:

[https://www.cax-if.de/xml-schema/3001/20170810/bom\\_20170810.xsd](https://www.cax-if.de/xml-schema/3001/20170810/bom_20170810.xsd)

The corresponding name space definition is given in the aforementioned Recommended Practices, Section 1.1.2.

**Note:** It is planned to update the Recommended Practices to support AP242 Edition 2 Domain Model XML. With the imminent release of the final schemas in early July, the AP242 XML Rec. Practices will be updated accordingly shortly after. Vendors are encouraged to upgrade immediately, as far as time and resources permit.

The Kinematic capabilities for AP242 XML are developed jointly by the CAX-IF and the JT-IF, thus supporting Aerospace as well as Automotive requirements, and also broadening the scope of participating STEP translators. To ease the exchange of the files, the part geometry files for the KM2 test model are available in STEP AP242 Part 21 as well as ISO JT (JT v9.5) format, so the AP242 XML file references can easily be adapted for the preferred geometry format.

Based on this approach, Kinematic test files...

- ...from JT-IF Round 21 (February – June 2021) will be carried over to CAX-IF R48J.
- ...from CAX-IF R48J will be handed over to JT-IF Round 22 (August – November).

### 2.2.3 Testing Instructions

In Round 48J, the Kinematics test model originally developed by Stefani Maschinenbau and provided by Audi and Volkswagen via the prostep ivip / VDA JT Workflow Forum will be used again. It represents a gripper tool used in a production line assembly. This production-like model is used for internal pilot projects at Volkswagen and Audi and is being shared with the implementor forums for testing exclusively within these groups.

- The native CATIA version of the “Gripper” has been modeled by :em engineering methods on behalf of Audi. The ZIP package also contains an HTML breakdown of the model contents, also created by :em engineering methods.
- The native NX version of the “Gripper” has been modeled by Siemens PLM on behalf of Audi.
- The native CATIA and NX models are available in the CAX-IF member area under “Information on Round 48J of testing”. Please make sure to use the latest version (upload date 6 July 2021).

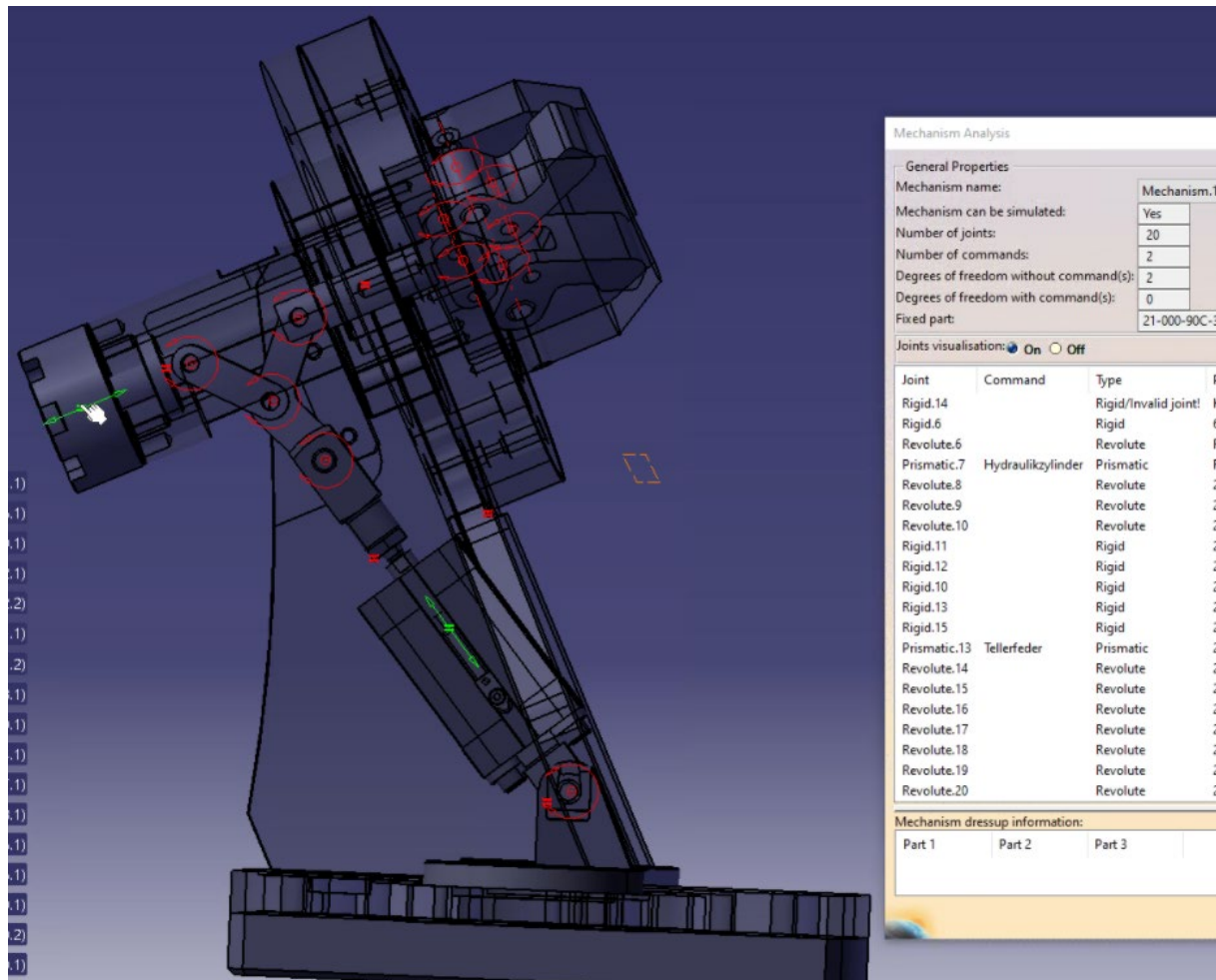

Figure 2: Illustration of the KM2 test model with indicated kinematic pairs

**Note** that the models also contain PMI but checking these is out of scope for the KM2 test case, which solely focuses on the Kinematic definitions.

The following is in scope of Round 48J:

- Kinematic Motion provides discrete positions of the moving components with a time index and can be played back like a stop-motion animation. This capability is aimed mostly at viewing and long-term archiving scenarios because it does not require the target application to have a kinematic solver.
- Kinematic Mechanism includes the definition of kinematic pairs (joints and constraints) and actuators. The goal is that the mechanism is editable in the target system, while preserving the dependencies defined in the original system.
- Assembly & Kinematic Data shall be provided in a single AP242 XML file.
- Geometry shall be included as STEP AP242 Part 21 precise B-Rep files.

**Note** that the Kinematic capabilities (Mechanism as well as Motion) are tested in cooperation with the JT Implementor Forum, in order to increase the number of participating systems and to enable exchange of data between different systems. This requires replacing the geometry files as well as the file references in the AP242 XML file but has no impact on the actual Kinematic capabilities.

## 2.2.4 Statistics

For each STEP file exported or imported for the KM2 test case, vendors must submit the corresponding statistics. To do so, go to the [ KM2 Data Sheet ], and either fill in the web form, or upload a comma-delimited file (.csv) with the data as listed below.

### Native Statistics

When exporting a STEP file, report what data importing systems should expect to find. For numeric statistics, enter the respective value or 'na' if not supported. For other statistics, select 'full support' (i.e. test case and Rec. Pracs. definitions are fulfilled), 'limited support' (meaning the implementation does not meet all criteria and issues may be expected on import), or 'na' if not supported.

### Target Statistics

When importing a file, report the results found after processing the file as described below.

### Kinematics-specific Statistics

For more detailed information about and discussion of in the Kinematics-specific statistics, please refer to section 4.12 of the Kinematics Recommended Practices mentioned above.

## Data Sheet Columns

column name	description
<b>model</b>	The name of the test model, here 'km2'
<b>system_n</b>	The system code of the CAD system creating the STEP file
<b>system_t</b>	The system code of the CAD system importing the STEP file. For native stats, select 'stp'
<b>assem_struct</b>	pass/fail – if the model structure (assembly tree) was transferred correctly, i.e. no nodes have been added or removed, and all elements are on the correct hierarchical level.
<b>kin_motions</b>	The number of Kinematic Motions defined in the model
<b>kin_motion_paths</b>	The number of paths defined for a Kinematic Motion
<b>kin_mechanisms</b>	The number of Kinematic Mechanisms defined in the model
<b>kin_mech_pairs</b>	The number of low/high order Kinematic Pairs defined for a Kinematic Mechanism
<b>kin_revolute_pairs</b>	The number of Revolute Pairs defined for Kinematic Mechanisms
<b>kin_cylindrical_pairs</b>	The number of Cylindrical Pairs defined for Kinematic Mechanisms
<b>kin_planar_pairs</b>	The number of Planar Pairs defined for Kinematic Mechanisms
<b>kin_mech_acts</b>	The number of Kinematic Pairs that have a non-zero value in the attribute 'actuation', i.e. where an initial movement can occur
<b>date</b>	The date when the statistics were last updated (will be filled in automatically)
<b>issues</b>	A short statement on issues with the file

## 2.3 Test Case UD4: User Defined Parameters

All information about this test case can also be viewed in CAESAR on its Information page.

### 2.3.1 Motivation

CAD models often contain user-defined parameters which define additional properties on the part. These can be parameters which drive the geometry (parametric definition), or engineering notes, requirements and custom properties that are relevant for downstream processes such as manufacturing.

These properties are typically authored in the source CAD systems and need to be transferred in a way that target applications can identify and process them in such a way that they make the appropriate decisions and derive relevant information for downstream use.

The CAX-IF User Group has defined several user stories related to user-defined properties and user-defined parameters at the part level as well as at the geometry level. The UD4 test case in Round 48J serves as an acceptance test for these user stories.

While the exact naming, structuring and association of these parameters to model elements – at part level as well as geometry level – differs between the different CAD systems based on their respective internal data models, they can be mapped to common concepts in STEP.

### 2.3.2 Approach

The approach for transferring user-defined properties and parameters with STEP AP242 is described in the “Recommended Practices for User Defines Attributes”, version 1.8 (18 February 2021), which is available on the public web site of the CAX-IF Implementor Group. Specifically, section 5.3 of this document, which was newly introduced with version 1.7, provides the necessary classification mechanism to properly identify user-defined parameters and properties.

The precise mapping recommendation for testing user defined properties and parameters in Round 48J is as follows (all based on section 5.3 of the Recommended Practices):

- `id_attribute.attribute_value = 'general property'`
- `property_definition.description =`
  - 'customized PDM property' (for user defined properties)
  - 'user defined attribute' (for user defined parameters)

The schema to be used is the AP242 Edition 2 IS schema, available in the public area of the CAX-IF Implementor Group web page.

### 2.3.3 Testing Instructions

The CAX-IF User Group has provided a set of native CATIA V5 test models with pre-defined parameters and properties. These are available in a ZIP package from the member area of the CAX-IF web sites, under “Information on Round 47J of Testing.”

- The test model "ParameterTestPart\_simplified.CATPart" contains the basic parameters described in Figure 3 below.
- In addition, the test model "Parameter Test Part.CATPart" contains the complete set of Parameters/Properties that can be used.

**Note** that while it is the intention to test this capability across different CAD systems, the CAX-IF user group so far provided native models only for CATIA V5. Thus, in Round 48J:

- CATIA / 3DEXperience – STEP interfaces shall map the user defined properties and parameters as defined above, maintain their semantics on export and import

- STEP translators for other CAD systems shall import the generated files and report their experiences on how they map the data.

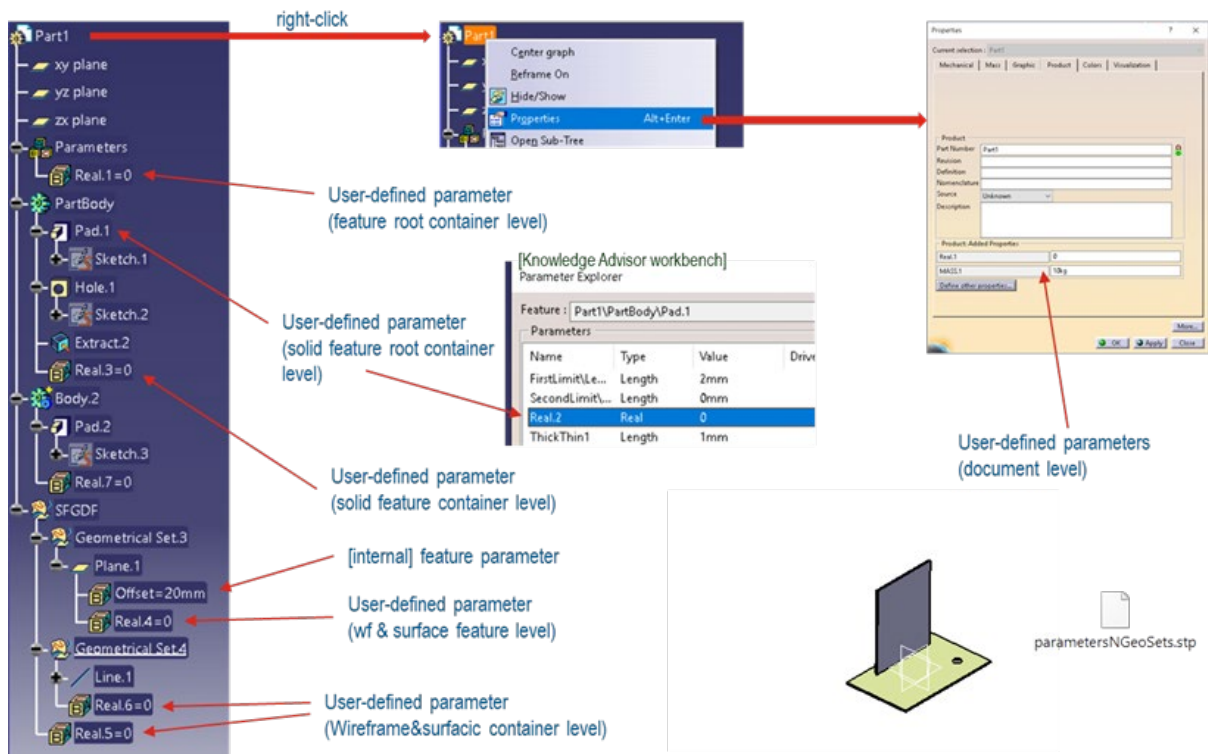

Figure 3: Overview on User-Defined Parameters and Properties defined in the test model

### 2.3.4 Statistics

For each STEP file exported or imported for the UD4 test case, vendors must submit the corresponding statistics. To do so, go to the [ UD4 Data Sheet ], and either fill in the web form, or upload a comma-delimited file (.csv) with the data as listed below.

#### Native Statistics

When exporting a STEP file, report what data importing systems should expect to find. For numeric statistics, enter the respective value or 'na' if not supported. For other statistics, select 'full support' (i.e. test case and Rec. Pracs. definitions are fulfilled), 'limited support' (meaning the implementation does not meet all criteria and issues may be expected on import), or 'na' if not supported.

#### Target Statistics

When importing a file, report the results found after processing the file as described below.



## Data Sheet Columns

column name	description
<b>model</b>	The name of the test model, here 'ud4'
<b>system_n</b>	The system code of the CAD system creating the STEP file
<b>system_t</b>	The system code of the CAD system importing the STEP file. For native stats, select 'stp'
<b>ud_param_part</b>	pass / fail, have the user defined parameters at part / product level been transferred correctly?
<b>ud_prop_part</b>	pass / fail, have the user defined properties at part / product level been transferred correctly?
<b>ud_param_solid</b>	pass / fail, have the user defined parameters for solids been transferred correctly?
<b>ud_param_geoset</b>	pass / fail, have the user defined parameters for CATIA geometric sets been transferred correctly?
<b>ud_param_scp</b>	pass / fail, have the user defined parameters for surfaces, curves and points been transferred correctly?
<b>valid_attr</b>	pass/fail, is the instantiation of the User Defined Attributes as per the Recommended Practices?
<b>uda_part_vp</b>	pass/fail, has the number of User Defined Attributes at the Part/Product level been processed correctly? This includes UDA VP at assembly component instances and for groups of UDA.
<b>uda_geo_vp</b>	pass/fail, has the number of User Defined Attributes at the Geometry level been processed correctly?
<b>uda_type_vp</b>	pass/fail, has the number of User Defined Attributes per attribute type class (boolean/integer/real/string) been processed correctly?
<b>date</b>	The date when the statistics were last updated (will be filled in automatically)
<b>issues</b>	A short statement on issues with the file

## 2.4 Test Case AS3: AP242 Edition 2 Minor Revision Domain Model XML

All information about this test case can also be viewed in CAESAR on its Information page.

### 2.4.1 Motivation

The exchange of assembly structures with external references to geometry files is a long-used concept in the STEP multiverse, which has proven its value and stability in many business use cases. In addition to the long-used Part 21 representation, AP242 provides a Business Object (BO) Model with a comprehensive data model in an XML representation.

AP242 XML is the designated standard process format for the automotive and aerospace industries and will be used together with various standardized and proprietary geometry file formats, depending on the actual use case. Over time, this test case evolved to include external references to 3D Tessellated Geometry, Assembly Validation Properties and User Defined Attributes.

After the publication of the first AP242 Business Object Model as International Standard in 2014, improvements to the data model were made and published as a Technical Corrigendum (TC) in 2016. This is the current basis for implementation.

In April 2020, the second Edition of AP242 was published, which brought with it many changes in the underlying architecture of the standard as well as extended functionalities. However, some limitations and issues remained with the data model. These have now been resolved with the AP242 Edition 2 Minor Revision (MR). While the standards document is currently going through the release process, the final implementation schemas and updated Recommended Practices are available for vendors to update their translators.

In Round 48J, this test case is dedicated to the migration towards AP242 E2 MR.

Only AP242 E2 MR files will be accepted for testing in the AS3 test case.

### 2.4.2 Approach

The following schemas and documents shall be used for this test:

- AP242 Edition 2 Minor Revision Domain Model XML – Close-to-release versions of the schemas are available in [R48J]. None of the pending changes will affect this test.
- Recommended Practices for AP242 Edition 2 Minor Revision Domain Model XML Assembly Structure, version 2.99.03 [R48J]
- AP242 IS Longform Schema (v1.101), dated July 1, 2019 [JTI]

The documents can be found in the following locations, as indicated:

- [JTI] – Public CAX-IF Homepage, “Joint Testing Information”
- [R48J] – CAX-IF Member Area, “Information on Round 48J of Testing”

The focus of this test is the assembly structure exchanged in AP242 XML format. The test has the following degrees of freedom:

- **File structure:**
  - "all in one" - one XML file for the entire assembly structure, plus one STEP file per component part
  - "nested" - one XML file for each node in the assembly tree, plus one STEP file per component part. Note that in this case, component parts with part-level User Defined Attributes require an additional Domain Model XML sidecar file containing these properties; see Recommended Practices section 9.3.
- **Geometry format:**
  - Precise B-Rep (STEP AP242) or Tessellated Geometry (STEP AP242)

### 2.4.3 Testing Instructions

The test model to be used in Round 48J is the "Torque Converter", known from previous Benchmarking activities. Native CAD files are available for it in the following formats:

- CATIA V5
- Creo
- NX

They can be found in the File Repository within the member area of the CAX-IF web sites, in the folder *"CAD/Round 41J/Torque Converter"*.

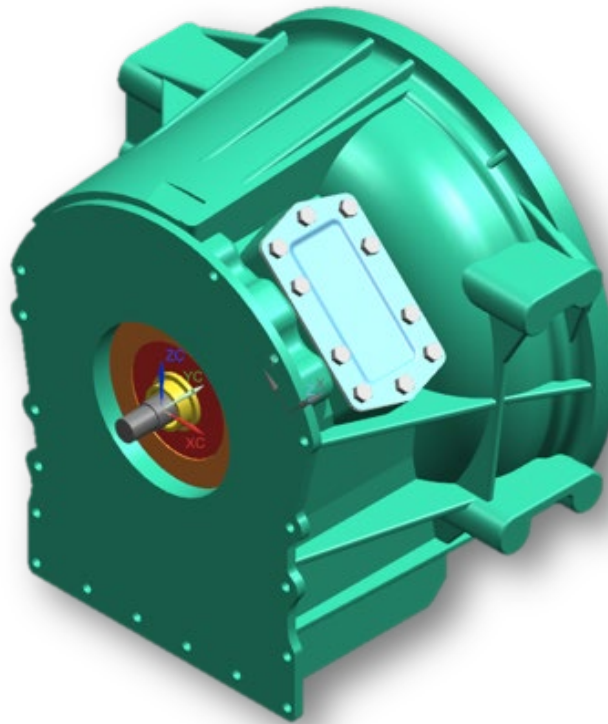

*Figure 4: Illustration of the Torque Converter model*

The aim of this test is to correctly transfer the assembly structure based on AP242 Edition 2 Minor Revision Domain Model XML files, using either the "all-in-one" or the "nested" approach, and referencing tessellated parts.

Since transfer of the AS3 geometry itself can safely be considered stable, there will be no geometry-related statistics. The evaluation will focus on completeness and correctness of the assembly structure and the external references.

The assembly files shall contain Assembly Validation Properties for all nodes in the product structure. The two values – number of children, and notional solids centroid – and their representation are defined in section 13.1 of the AP242 Edition 2 Minor Revision Domain Model XML Assembly Structure Recommended Practices.

In addition, all CAX-IF members supporting User Defined Attributes shall transfer the ones included in the native files (see below) at part level (section 12.5.1 of the Recommended Practices).

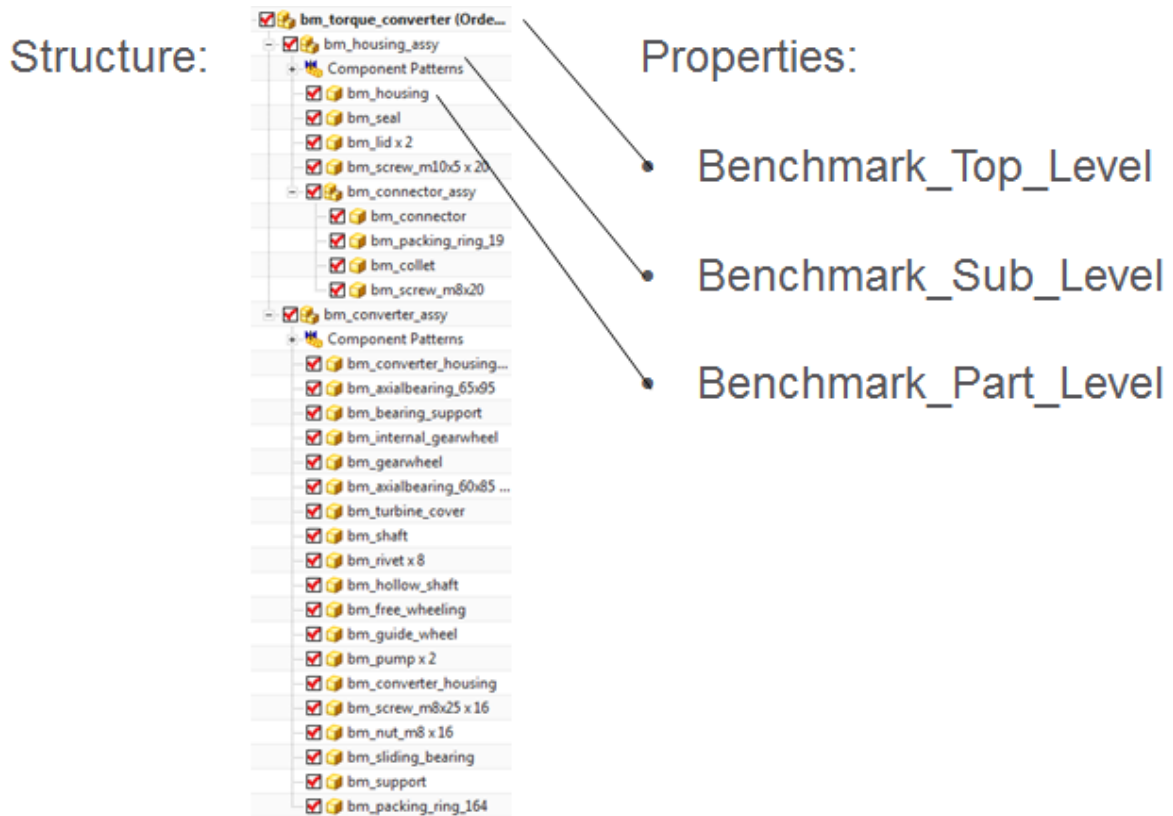

Figure 5: Torque Converter structure and indication if included attributes

## 2.4.4 Statistics

For each STEP file exported or imported for the AS3 test case, vendors must submit the corresponding statistics to CAESAR. To do so, go to the [ AS3 Data Sheet ], and either fill in the web form, or upload a comma-delimited file (.csv) with the data as listed below.

### Native Statistics

When exporting a STEP file, report what data importing systems should expect to find. For numeric statistics, enter the respective value or 'na' if not supported. For other statistics, select either 'full support' (i.e. test case and Rec. Pracs. definitions are fulfilled), 'limited support' (meaning the implementation does not meet all criteria and issues may be expected on import), or 'na' if not supported.

### Target Statistics

When importing a STEP file, report the results found after processing the file as described in the table below.

## Data Sheet Columns

column name	description
<b>model</b>	The name of the test model, here: 'AS3'
<b>system_n</b>	The system code of the CAD system creating the STEP file
<b>system_t</b>	The system code of the CAD system importing the STEP file. For native stats, enter 'stp'
<b>fref_found</b>	all/partial/none - indicates if all, some or none of the references to the external files can be found in the assembly structure file(s), and if they are correctly associated with the respective nodes in the assembly structure.
<b>fref_processed</b>	all/partial/none - indicates if all, some or none of the referenced files were processed correctly to successfully construct the overall model.
<b>assem_struct</b>	pass/fail - if the model structure (assembly tree) was transferred correctly, i.e. no nodes have been added or removed, and all elements are on the correct hierarchical level.
<b>assem_place</b>	all/partial/none - whether the placement of assembly components is correct
<b>children</b>	pass/fail, indicates whether the number of children for each node in the assembly tree matches the AVP value given in the STEP file
<b>valid_child</b>	pass/fail, is the instantiation of the validation property 'number of children' in the STEP file as per the recommended practices for validation properties?
<b>notional_solids</b>	all/partial/none, whether the position of all, some or none of the assembly components in the model could be validated through the 'notional solids' AVP.
<b>valid_notion</b>	pass/fail, is the instantiation of the validation property 'notional solids' in the STEP file as per the recommended practices for validation properties?
<b>part_attr</b>	pass/fail, have the User Defined Attributes at the part/product level been processed correctly?
<b>date</b>	The date when the statistics were last updated (will be filled in automatically)
<b>issues</b>	A short statement on issues with the file

## 2.5 Test Case CO2: Composite Materials (Ply Contour)

All information about this test case can also be viewed in CAESAR on its Information page.

### 2.5.1 Motivation

For several years, some STEP composite interfaces have been available in several CAD tools such as CATIA V5, FiberSIM and in CT CoreTechnologie tools, with a certain level of maturity proven by LOTAR pilot projects.

The goal of including Composite Materials in a CAx-IF test round is to align these implementations and provide an official framework for composite materials implementation tests as STEP AP 242e2 since it includes this capability.

### 2.5.2 Approach

The scope of this test case is the “exact implicit” representation of composites where the ply geometry is based on surfaces and contours. “Basic” composite validation properties at the part level are also in scope of this test case. The approximate explicit representation of composite plies, where there is a 3D tessellated solid for each ply, is out of scope for this test case.

The approach is to export and to import composite information in STEP AP242 based on the:

- AP242 Edition 2 IS Longform Express Schema, available on the CAX-IF homepage under “Public Testing Information”.
- Recommended Practices for Composite Materials; Version 4.1; 10 March 2021; available in the CAX-IF member area under “Information Round 47J of Testing.”
- Draft Recommended Practices for Composite Structure Validation Properties; Release 0.18; 28 March 2021; in the CAX-IF member area under “Information Round 48J of Testing.”
- **Note:** As the validation properties recommended practices have not been completely agreed upon, some tests will be done by end user checks.

### 2.5.3 Testing Instructions

The test case CPD\_PUBLIC\_LOTAR.CATPart will be used. The model has been provided by Airbus Helicopter.

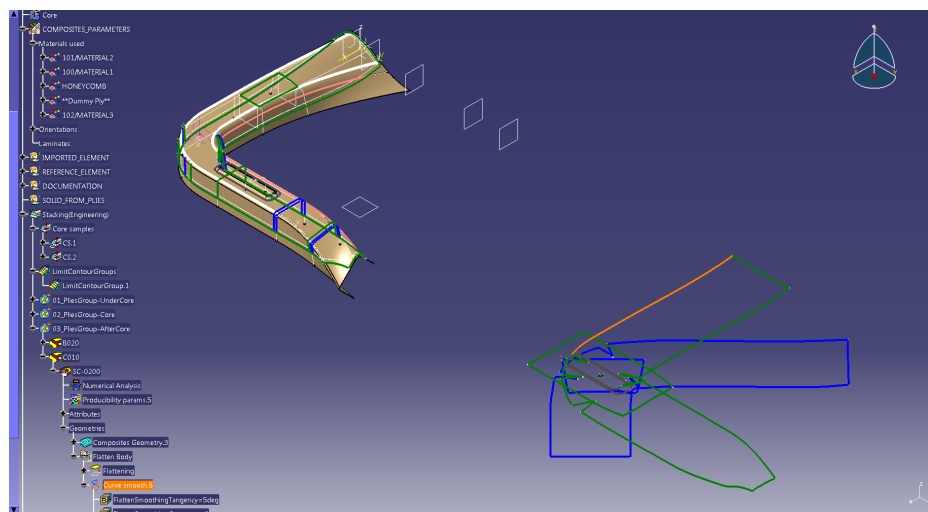

Figure 6: Illustration of the CO2 Test Case

The test case is available in the member area of the CAX-IF homepages, under “Information on Round 40J of Testing”.

### 2.5.4 Statistics

For each STEP file exported or imported for the CO2 test case, vendors must submit the corresponding statistics. To do so, go to the [ CO2 Data Sheet ], and either fill in the web form, or upload a comma-delimited file (.csv) with the data as listed below.

#### Native Statistics

When exporting a STEP file, report what data importing systems should expect to find. For numeric statistics, enter the respective value or 'na' if not supported. For other statistics, select either 'full support' (i.e. test case and Rec. Pracs. definitions are fulfilled), 'limited support' (meaning the implementation does not meet all criteria and issues may be expected on import), or 'na' if not supported.

#### Target Statistics

When importing a file, report the results found after processing the file as described below:

#### Ply-related Statistics

Several of the Statistics for this test case are related to a specific ply within a specific sequence (e.g., material, orientation, rosette). The statistics cannot evaluate this for all plies in the model. Hence, the idea is to select one specific (interesting) sequence and ply on export, and to publish its name in the "Composite Ply Sequence" field of the statistics. Then, fill in the other ply-related statistics with the values as valid for this particular sequence and ply. After import,

select the sequence and ply with the name given in the native statistics, and again provide the values valid for this particular sequence and ply.

The sequence and ply to be used for evaluating the CO2 test case in Round 46J is:

**PLY SC-0035 of SEQUENCE A035**

### Statistics for Core Sample Point

The position of the point for the Core Sample shall be given for:

**CORE SAMPLE CS1**

### Statistics for Flatten Pattern

The length of the curve contour of the flatten pattern shall be given for:

**PLY SC0200 of SEQUENCE C010**

### Data Sheet Columns

These statistics will be enhanced in future test rounds, especially with the release of newer versions of the Recommended Practices for Composite Structure Validation Properties.

column name	description
<b>model</b>	The name of the test model, here 'CO2'
<b>system_n</b>	The system code of the CAD system creating the STEP file
<b>system_t</b>	The system code of the CAD system importing the STEP file. For native stats, select 'stp'
<b>unit</b>	The unit the model is designed in
<b>compos_tables</b>	The number of Composite Tables in the Model
<b>sequences</b>	The number of Sequences in the model
<b>plies</b>	The total number of plies in the file
<b>num_materials</b>	Total number of Materials defined
<b>compos_table_name</b>	The name of the Composite Table of the model
<b>ply_sequence</b>	The ID of the Sequence and the ID of the Ply within that Sequence for all ply-related statistics; e.g., "Ply.P4 of Sequence.S4".
<b>seq_ply_number</b>	The total number of Plies defined within the Sequence as listed in the "Composite Ply Sequence" column of the data sheet.
<b>seq_ply_material</b>	The name of the Material of the specific Ply and Sequence as listed in the "Composite Ply Sequence" column of the data sheet.
<b>seq_ply_mat_type</b>	The type of Material of the specific Ply and Sequence as listed in the "Composite Ply Sequence" column of the data sheet.
<b>seq_ply_orient</b>	pass/fail - whether the orientation of the specific Ply and Sequence as listed in the "Composite Ply Sequence" column of the data sheet was correct
<b>seq_ply_rosette</b>	The name of the Rosette of the specific Ply and Sequence as listed in the "Composite Ply Sequence" column of the data sheet.
<b>ply_surface_area</b>	The value of the area of the specific Ply and Sequence as listed in the "Composite Ply Sequence" column of the data sheet.
<b>num_core_samples</b>	The total number of core samples in the file
<b>cs_pointx</b>	Position of the point for the Core Sample indicated in the Test Suite.
<b>cs_pointy</b>	

column name	description
<b>cs_pointz</b>	
<b>fp_length</b>	The length of the curve contour of the Flatten pattern of the ply and sequence indicated in the Test Suite document.
<b>validation_c_tables</b>	Total number of Composite Tables in the model, as received via the validation properties capability
<b>validation_sequences</b>	Total number of Sequences as received via the validation properties capability
<b>validation_plies</b>	Total number of Plies (entire assembly) as received via the validation properties capability
<b>validation_c_materials</b>	Total number of Materials as received via the validation properties capability
<b>validation_c_orient</b>	pass/fail, indicates whether the Number of Orientations per part in the model matches the Composite validation property value given in the STEP file
<b>validation_ply_area</b>	pass/fail, indicates whether the sum of all ply surface areas in the part matches the Composite validation property value given in the STEP file
<b>validation_ply_centroid</b>	pass/fail, indicates whether the sum of all ply geometric centroids in the part matches the Composite Validation Property value given in the STEP file
<b>valid_cvp</b>	pass/fail, is the instantiation of the validation properties for Tessellated Geometry in the STEP file as per the recommended practices?
<b>date</b>	The date when the statistics were last updated (will be filled in automatically)
<b>issues</b>	A short statement on issues with the file

## 2.6 Test Case CO4: Composite Parts with Multiple Rosette

All information about this test case can also be viewed in CAESAR on its Information page.

### 2.6.1 Motivation

For several years, some STEP composite interfaces have been available in several CAD tools such as CATIA V5, FiberSIM and in CT CoreTechnologie tools, with a certain level of maturity proven by LOTAR pilot projects.

The goal of including Composite Materials in a CAX-IF test round is to align these implementations and provide an official framework for composite materials implementation tests as STEP AP242 Edition 2 includes this capability.

The CAX-IF User Group created a user story with the requirement to convert a composite part with multiple rosettes within a ply group to STEP in a way that preserves the design intent.

### 2.6.2 Approach

For multiple rosettes inside the same ply group, the aim of the test is to take two plies inside the same ply group that do not have the same rosette, then to check that after STEP export/import that this is still the case.



As an example, in the given test case (see Figure 7 below),

- Ply “Ply.5” has the rosette “Rosette - Pad 1”
- Ply “Ply.6” has the rosette “Rosette - Pad 3”
- Plies “Ply.3” and “Ply.5” are both in the same group “Laminate Table 1 - Multiple Rosette Example”

The basis for implementation of the CO4 test case is the following:

- AP242 Edition 2 IS Longform Express Schema, available on the CAX-IF homepage under “Public Testing Information”.
- Recommended Practices for Composite Materials; Version 4.1; 10 March 2021; available in the CAX-IF member area under “Information Round 47J of Testing.”

### 2.6.3 Testing Instructions

The test case MultipleRosettesUseCase\_RevA.CATPart will be used. The model has been provided by the CAX-IF User Group.

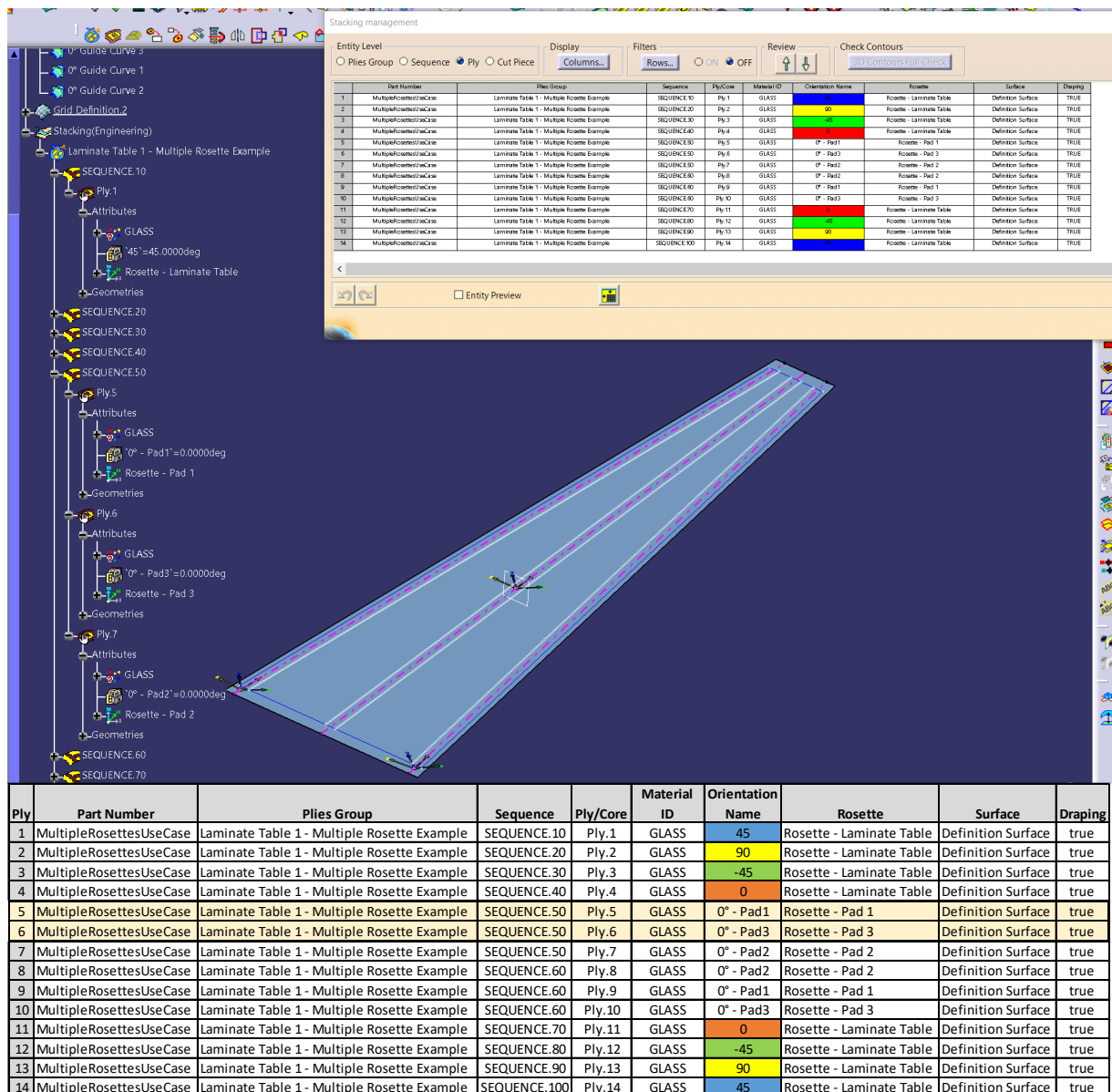

Figure 7: Illustration of the CO4 Test Case and Laminate Table

The test case is available in the member area of the CAx-IF homepages, under “Information on Round 48J of Testing”.

## 2.6.4 Statistics

For each STEP file exported or imported for the CO4 test case, vendors must submit the corresponding statistics. To do so, go to the [ CO4 Data Sheet ], and either fill in the web form, or upload a comma-delimited file (.csv) with the data as listed below.

### Native Statistics

When exporting a STEP file, report what data importing systems should expect to find. For numeric statistics, enter the respective value or 'na' if not supported. For other statistics, select either 'full support' (i.e. test case and Rec. Pracs. definitions are fulfilled), 'limited support' (meaning the implementation does not meet all criteria and issues may be expected on import), or 'na' if not supported.

### Target Statistics

When importing a STEP file, report the results found after processing the file as described in the table below.

### Ply-related Statistics

Several of the Statistics for this test case are related to a specific ply within a specific sequence (e.g., material, orientation, rosette). The statistics cannot evaluate this for all plies in the model. Hence, the idea is to select one specific (interesting) sequence and ply on export, and to publish its name in the "Composite Ply Sequence" field of the statistics. Then, fill in the other ply-related statistics with the values as valid for this particular sequence and ply. After import, select the sequence and ply with the name given in the native statistics, and again provide the values valid for this particular sequence and ply.

The plies group to be used for evaluating the CO4 test case in Round 48J is:

**Laminate Table 1 - Multiple Rosette Example**

The plies to be used for evaluating the CO4 test case in Round 48J are:

**PLY.5, PLY.6**

### Data Sheet Columns

column name	description
<b>model</b>	The name of the test model, here 'CO4'
<b>system_n</b>	The system code of the CAD system creating the STEP file
<b>system_t</b>	The system code of the CAD system importing the STEP file. For native stats, select 'stp'
<b>unit</b>	The unit the model is designed in
<b>compos_tables</b>	The number of Composite Tables in the Model
<b>compos_table_name</b>	The name of the Composite Table of the model
<b>plies</b>	The total number of plies in the model
<b>plies_groups</b>	The total number of plies groups in the model
<b>rosettes_pg</b>	The number of rosettes in the plies group selected for this test
<b>multi_rosettes</b>	pass/fail, do the selected plies within the same plies group have multiple rosettes assigned.

column name	description
date	The date when the statistics were last updated (will be filled in automatically)
issues	A short statement on issues with the file

## 2.7 Test Case PID: Persistent IDs

All information about this test case can also be viewed in CAESAR on its Information page.

### 2.7.1 Motivation

The ability to track a product's model information during design iteration, and from design iteration through to manufacturing and quality analysis has been limited by the lack of support for persistent IDs in STEP.

With the inclusion of persistent IDs in STEP, collaborating systems should now be able to exchange model data and track that data during design iteration. This suggests the ability to retain IDs contained in external data from a sender and reference those entities by the receiver. When a change to that model data occurs on the sender's side, the receiver should be able to update the receiver's copy of that external data and have any dependent data in their own models that refer to that external change, and update to respond to the change.

As in the case of design iteration, the ability to track model entities via persistent IDs, will also allow downstream systems to update their representations of the design model and update their manufacturing and metrology planning to reflect changes in the design.

An additional benefit of the establishment of persistent IDs in STEP is the ability to retain a permanent audit trail of custody and connection between design and downstream systems for potential forensic analysis of critical product systems after in-service failure.

Finally, although not covered in this first test case, the introduction of persistent IDs provides the ability of any contributor to the information stream associated with a product's lifecycle to add information to the model that can be connected to existing model content and that additional information can be retrieved by subsequent users and used as feedback from the contributor.

### 2.7.2 Approach

The approach to be used is described in the "Recommended Practices for Permanent Entity IDs for Design Iteration and Downstream Exchange" (Version 0.5; 29 May 2020), which can be found in the CAX-IF member area under "Information on Round 46J of Testing".

Within the domain of Persistent IDs, the following functionalities are in scope of Round 48J:

- Persistent IDs on Model (Product) for
  - testing the retention of model ID after changes in the underlying content
- Persistent IDs on Geometry for
  - testing the effect of a change in geometry and topology on dependent manufacturing planning that references that geometry and topology
  - testing the effect of a change in geometry and topology on dependent metrology planning that references that geometry and topology
  - this concept includes the introduction of Persistent IDs on Shape Aspect as they are used to collect individual geometry elements into logical groups for some downstream purposes

- Persistent IDs on Semantic PMI Representation for
  - testing the effect of changes in semantic PMI on dependent manufacturing planning that reference that semantic PMI
  - testing the effect of changes in semantic PMI on dependent metrology planning that reference that semantic PMI
- Persistent IDs on UDAs for
  - testing the effect of changes in UDAs attached to model, semantic PMI, or geometry on dependent manufacturing or metrology planning that reference that those UDAs

The following are out of scope for Round 48J and are moved to the Future Considerations section:

- Persistent IDs on Geometry and Persistent IDs on Semantic PMI Representation for
  - testing assembly constraints referencing those geometries
  - testing the effect of change in geometry and topology on dependent shape that references that geometry and topology for design iteration

The preferred AP242 schema to be used is the AP242 Edition 2 IS schema, which can be found on the public CAX-IF web sites under “Public Testing Information”. As a fallback, the AP242 Edition 1 IS version can be used.

### 2.7.3 Testing Instructions

The tests will be performed based on an existing NIST test model, well known to the CAX-IF community, namely the NIST PMI test case FTC-09.

#### 2.7.3.1 Test Model Overview

The specific test model to be used in this test case is a modified version of the NIST FTC-09 test case for testing persistent IDs and the effect of model change on downstream manufacturing and metrology planning.

#### 2.7.3.2 Test Model Access

The native CAD files can be downloaded from the NIST homepage. See section 2.1.3.2 for details and direct download links.

#### 2.7.3.3 Test Model Configuration

Unlike any previous CAX-IF test round, the PID test case requires iteration to confirm retention of persistent entity IDs. This iteration process implies a minimum of two exchanges – an initial exchange and a subsequent exchange. Test cases for downstream use variants of the NIST Test Case FTC-09 (see Annex B). The two iterations will be identified by model suffixes in CAESAR (PID\_1 – Initial Exchange; PID\_2 – Subsequent Exchange).

**Note** also that there are two mechanisms for supporting the introduction of persistent IDs to STEP. The first is via the creation of new persistent `id_attribute` entities attached to certain entities within the Data Section of the Part 21 file. The second is via the creation of persistent ID relationships between STEP entity IDs and persistent entity IDs within an Anchor Section of a Part 21 Edition 3 file. Please refer to the recommended practice document for further details about the valid entity types to be used with `id_attribute` entities in the Data Section. Based on agreement, the scope of Round 48J will include only the first type of ID, i.e. `id_attribute` in the Data Section. This is reflected in the current version of the Recommended Practices. The testing of the Anchor Section approach will be considered in a future test round.

### Test Case PID – Persistent Identifiers, via Data Section

The FTC-09 NIST model will be used, however we need to supplement the test case with additional information as follows.

Please add the following User Defined Attributes (UDAs):

- Attributes (UDAs) at the Product level in your native CAD model (taken from ASME 14.47, DRAFT, Feb 2018, Table 6-3 Metadata Elements (partial))

Element Name	Data Type	Description
CREATE_DATE	ISO 8601 extended form date/time	Date the data set was initially created.
MODEL_UNITS	String	System of units of measure (SI or U.S. Customary) of the model.
NOMENCLATURE	String	“NIST FTC09 Modified”
MODEL_PRECISION	Integer	Value that indicates numeric accuracy (number of significant digits) of model required in production of part in order for it to fulfill the design intent (ASME Y14.41).
REV	String	Current revision of the design per ASME Y14.35.

- Attributes (UDAs) on PMI (some PMI, not all):
  - UDA Name – “Severity Description”
  - UDA Type – String
  - UDA Value – “Critical”
  - UDA Name – “Severity Value”
  - UDA Type – Integer
  - UDA Value – 2

Please add the following Features (Shape Aspects):

- Collection of Geometries (surfaces) for the slotted hole (see Figure 8 below)

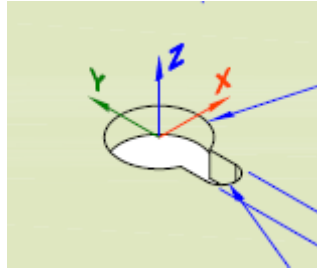

Figure 8: NIST FTC09, View C, slotted hole

## Preprocessor (CAD)

### Initial Iteration (PID\_1)

- Export FTC09 as modified above (including IDs on Product, Geometry, Shape Aspect, PMI, and UDA)

### Second Iteration (PID\_2)

Modify UDAs as follows:

- UDA Name – “REV”
- UDA Type – Real or Integer (see below)
- UDA Value – if the model contains a PLM version attribute, use that type and value; if not, use the integer type with value 2

Modify the hole geometry and tolerance info for the 3 instances of the hole shown in Figure 9:

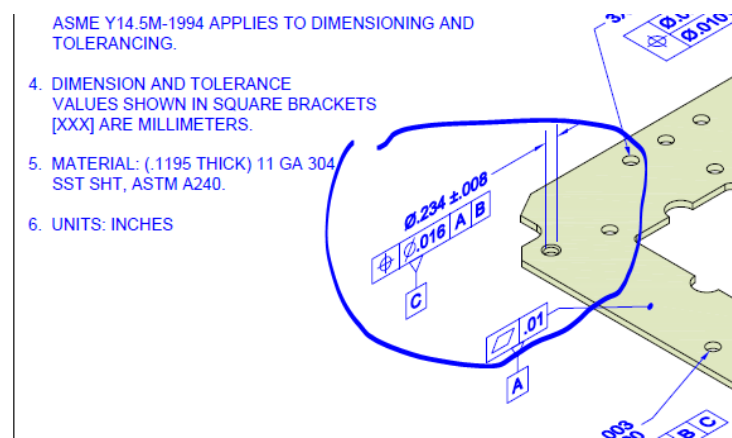

Figure 9: NIST Test Case FTC09, View A, Detail of Hole

- Change the three instances of 0.016 location tolerances to 0.014; add Criticality UDA on these two tolerances.
- Change the three nominal hole diameters from 0.234 to 0.236 and hole diameter tolerance values from 0.008 to 0.010

Slotted Hole (see Figure 10):

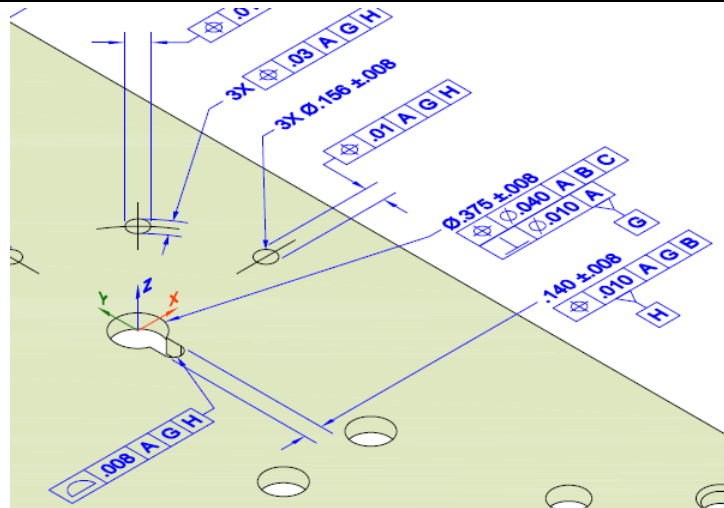

Figure 10: NIST Test Case FTC09, View C, Detail of Slotted Hole

- Change the hole diameter from 0.375 to 0.385, and
- Change the slot width from 0.140 to 0.150.

### Postprocessor (CAD System or Manufacturing and/or Metrology Planning System)

#### Initial Iteration (PID\_1)

- Import FTC09 and confirm receipt of Persistent IDs on Product, on Geometry, on Shape Aspect, on PMI, and on UDAs

#### Second Iteration (PID\_2)

Import revised FTC09 and confirm receipt of the same Persistent IDs on Product, on Geometry, on Shape Aspect, on PMI, and on UDAs as were received in PID1:

- Confirm change to location tolerance values
- Confirm retention of Criticality UDA on these tolerances
- Confirm change to hole diameters (geometry and nominal value) and hole diameter tolerance values; confirm aggregate and individual IDs on hole cylinders and their shape aspect
- Confirm change to slot geometry; Confirm aggregate and individual IDs on reference surfaces and their shape aspect

## 2.7.4 Statistics

For each STEP file exported or imported during one of the iterations of the PID test case, vendors must submit the corresponding statistics. To do so, go to the [ PID Data Sheet ], and either fill in the web form, or upload a comma-delimited file (.csv) with the data as listed below.

### Native Statistics

When exporting a STEP file, report what data importing systems should expect to find. For numeric statistics, enter the respective value or 'na' if not supported. For other statistics, select either 'full support' (i.e. test case and Rec. Pracs. definitions are fulfilled), 'limited support' (meaning the implementation does not meet all criteria and issues may be expected on import), or 'na' if not supported.

### Target Statistics

When importing a STEP file, report the results found after processing the file as described below.

## Data Sheet Columns

column name	description
<b>model</b>	The name of the test model, here 'PID'. <b>Important:</b> Add the iteration as suffix to the model, i.e.: <ul style="list-style-type: none"> <li>• PID_1 for the initial exchange</li> <li>• PID_2 for the subsequent exchange</li> </ul>
<b>system_n</b>	The system code of the CAD system creating the STEP file
<b>system_t</b>	The system code of the CAD system importing the STEP file. For native stats, select 'stp'
<b>pid_product</b>	pass/fail – whether the persistent ID at the product level was transferred correctly
<b>num_pid_pmi</b>	The number of semantic PMI elements processed with persistent IDs
<b>num_pid_topol</b>	The number of topological elements (e.g., <code>advanced_face</code> ) processed with persistent IDs
<b>num_pid_shape</b>	The number of <code>shape_aspects</code> processed with persistent IDs
<b>num_pid_uda</b>	The number of user defined attributes processed with persistent IDs
<b>downstream_update</b>	all/partial/none - indicates whether the receiving system was able to successfully update the references on subsequent iterations
<b>date</b>	The date when the statistics were last updated (will be filled in automatically)
<b>issues</b>	A short statement on issues with the file



## Annex A NIST Model Translation Configuration Considerations

Based on data translation issues identified in the NIST Phase 2 project (requiring multiple dataset submission iterations to resolve), the following translator configuration considerations have been derived for the PMI test case in Round 48J:

- Include annotations, coordinate systems, model properties, and PMI views
- Include supplemental geometry (non-solid surfaces, curves, points)
- Preserve annotation associations with both product and supplemental geometry
- Preserve annotation semantic PMI properties
  - Clearly point out if these are intentionally not translated
- Preserve annotation text
  - Creo should be configured to display dimension tolerances (tol\_display on)
  - Do not drop leading zeros or add trailing zeros
- Preserve annotation units
  - CTC 01, 02, and 04 are defined in millimeters
  - CTC 03 and 05 are defined in inches
  - FTC 06 through 09 models are defined in inches
  - FTC 10 and 11 models are defined in millimeters
- Preserve display names of annotations and coordinate systems
  - Point out if you use NX 9 or newer since this will change some of the annotation names (see Figure 11 below)
- Preserve display colors of product geometry, supplemental geometry, and annotations
- Preserve view-specific visibility of annotations, coordinate systems, and supplemental geometry:
  - In the ZIP files with the test case specifications (see links in section 2.1.3), there is a PDF named "*nist\_[ctc/ftc]\_suppl\_elem\_visibility.pdf*" which gives a detailed definition of which elements shall be visible in which view, and which not.
  - Note that for each test case, there is a second PDF document included in the ZIP files, named "*...\_elem\_ids.pdf*" which contains the element ids for unambiguous identification of all PMI.
- Preserve view frustum (orientation and zoom level) definition:
  - JT model views should be defined so they are listed in the "Model Views" menu of JT2Go and work properly when selected
- Do not export extraneous information
  - Only CATIA Captures (not Views) should be exported to STEP Saved Views
  - Creo sketch dimensions should only be included when visible in a Combined View

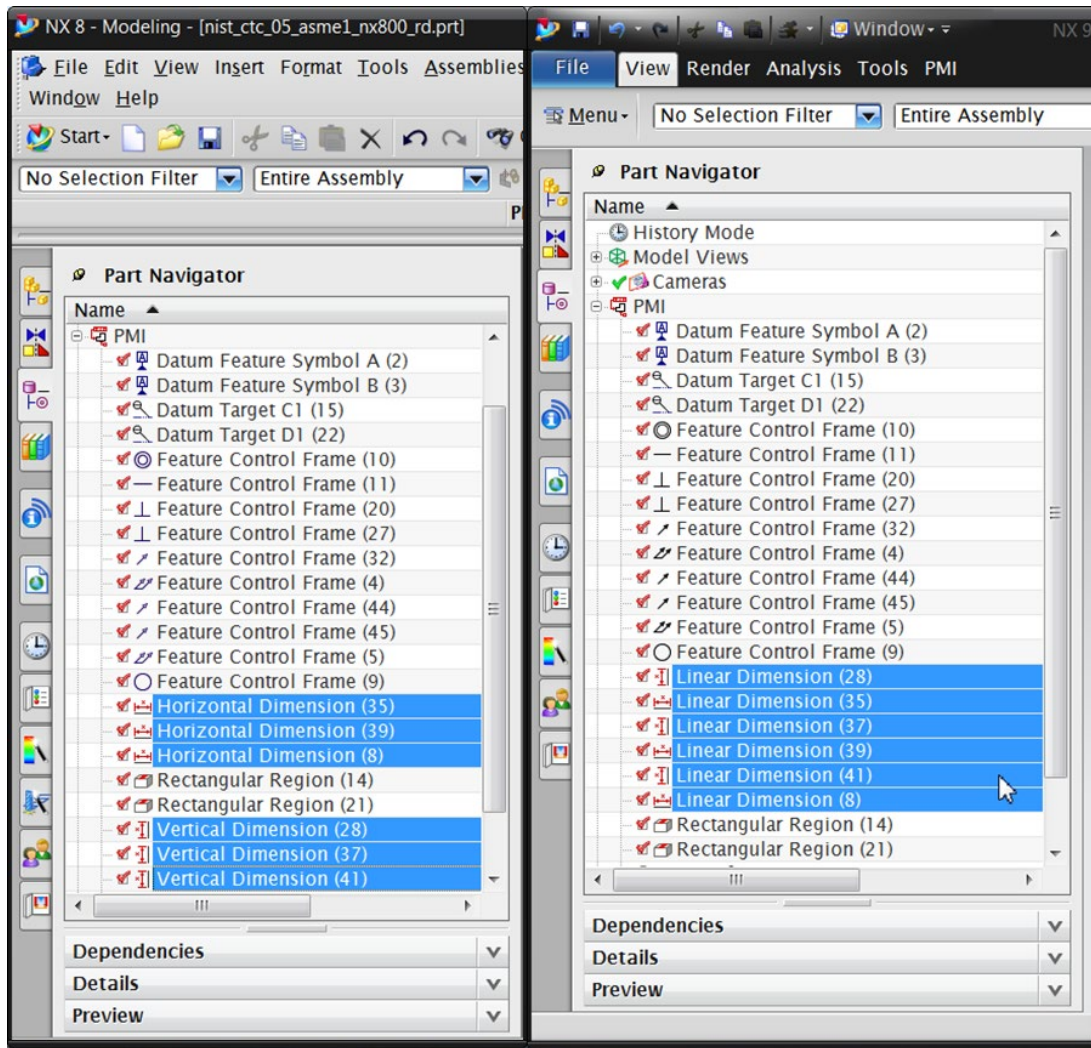

Figure 11: NX 8 vs. NX 9 Dimension Display Names

## Annex B NIST Model Definitions

This section provides an overview of the test models used for testing of PMI capabilities in Round 48J. All of these models have been developed in the course of NIST's "MBE PMI Validation and Conformance Testing Project". Information on this project and related activities can be found on internet at <https://go.usa.gov/mGVm>

The full suite of models consists of two data sets:

First, the so-called Complex Text Cases (CTC). These are the models with indices 01-05. They contain a collection of basic PMI constructs. Download the definitions from:

[https://s3.amazonaws.com/nist-el/mfg\\_digitalthread/NIST\\_CTC\\_Definitions\\_Dec\\_2016.zip](https://s3.amazonaws.com/nist-el/mfg_digitalthread/NIST_CTC_Definitions_Dec_2016.zip)

Second, the so-called Fully-toleranced Test Cases (FTC). These are the models with indices 06-11. They are fully defined models, providing all information required to actually manufacture and inspect the models. Download the definitions from:

[https://s3.amazonaws.com/nist-el/mfg\\_digitalthread/NIST\\_FTC\\_Definitions\\_Dec\\_2016.zip](https://s3.amazonaws.com/nist-el/mfg_digitalthread/NIST_FTC_Definitions_Dec_2016.zip)

In order to reduce the workload for the participating vendors, not all eleven models shall be tested in Round 48J. The following five models have been chosen:

- PMI: FTCs 6, 7, 8, 9, 10

This selection still covers a wide range of PMI elements, while reducing the number of exchanged to be done for each interface vendor. The models are indicated with a label below.

The illustrations below show the first page of the PDF document for each test model.

### NIST PMI Test Models - 2012

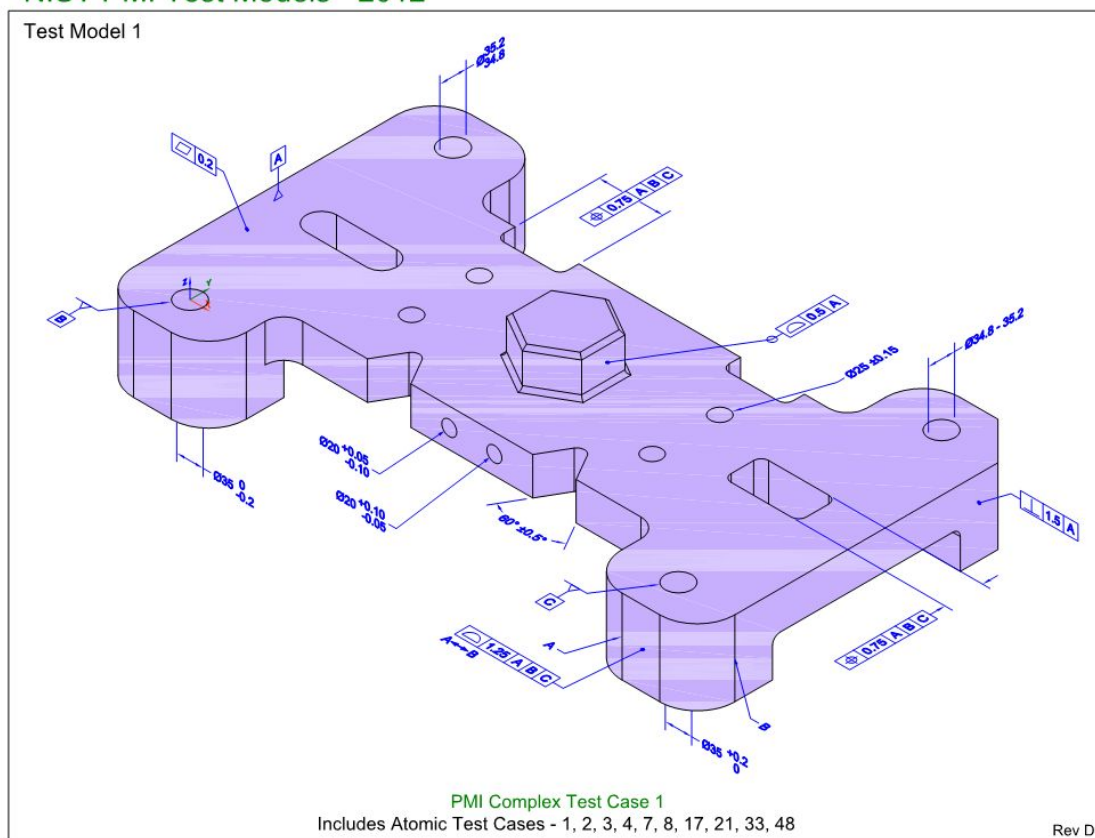

### NIST PMI Test Models - 2012

**Test Model 2**

**NOTES (UNLESS OTHERWISE SPECIFIED):**

- OBTAIN DIMENSIONS FOR ALL UNDIMENSIONED FEATURES FROM THE MODEL. ALL DIMENSIONS OBTAINED FROM THE MODEL ARE BASIC UNLESS OTHERWISE SPECIFIED.
- ASME Y14.41-2003 APPLIES TO DATASET.
- ASME Y14.5M-1994 APPLIES TO DIMENSIONING AND TOLERANCING.

These notes shall be placed on a static annotation plane (the plane does not rotate with the model).

The intent of ATC50 is to test systems' support for static annotation planes.

Including a feature control frame in a general note will be a test case in the next round of testing.

**PMI Complex Test Case 2 - View 1 (of 3)**  
 Includes Atomic Test Cases - 28, 29, 43, 47, 50

Rev C

nist\_ctc\_02\_asme1\_rc

### NIST PMI Test Models - 2012

**Test Model 3**

Datum Feature F not referenced - justifies placing MCS at center of large hole on flange

**PMI Complex Test Case 3**  
 Includes Atomic Test Cases - 6, 13, 14, 20, 27, 32, 36, 39, 45, 46

Rev C

nist\_ctc\_03\_asme1\_rc

NIST PMI Test Models - 2012

**Test Model 4**

This tolerance applies to the top surfaces above datum features G and H. The string "2 SURFACES" does not clarify which surfaces. Associativity will.

PMI Complex Test Case 4  
 Includes Atomic Test Cases - 5, 9, 10, 12, 15, 16, 22, 30, 40, 49

Rev D nist\_ctc\_04\_asme1\_rd

NIST PMI Test Models - 2012

**Test Model 5**

Notes  
 Datum feature B and  
 Datum target D1 defined  
 in View 2 (of 2).

PMI Complex Test Case 5 - View 1 (of 2)  
 Includes Atomic Test Cases - 11, 18, 19, 23, 24, 37, 42, 44

Rev D nist\_ctc\_05\_asme1\_rd

### NIST PMI Test Models - 2014

Feature and Specification Index  
R48J

NOTES (UNLESS OTHERWISE SPECIFIED):

- CAD MODEL \_\_\_\_\_ REV. \_\_\_ IS REQUIRED TO COMPLETE PRODUCT DEFINITION.
- DIRECTLY-TOLERANCED DIMENSIONS AND BASIC DIMENSIONS DEFINED ON THE DRAWING TAKE PRECEDENCE OVER DIMENSIONAL DATA DEFINED BY THE MODEL. OBTAIN ALL OTHER DIMENSIONAL DATA FROM THE MODEL. THE MODEL REPRESENTS BASIC DIMENSIONAL DATA UNLESS OTHERWISE SPECIFIED.
- APPLICABLE STANDARDS:  
 ASME Y14.41-2003 APPLIES TO DATASET.  
 ASME Y14.5M-1994 APPLIES TO DIMENSIONING AND TOLERANCING.
- $\text{[Symbol]} \text{[Tolerance]} \text{[A]} \text{[B]} \text{[C]}$  APPLIES TO ALL UNTOLERANCED SURFACES.
- UNITS: INCHES

**PMI Fully-Toleranced Test Case 6 - View A**  
 Includes Atomic Test Cases - 52, 53, 72, 87, 88, 89

Rev D

nist\_ftc\_06\_asme1\_rd

### NIST PMI Test Models - 2014

Feature and Specification Index  
R48J

NOTES (UNLESS OTHERWISE SPECIFIED):

- CAD MODEL \_\_\_\_\_ REV. \_\_\_ IS REQUIRED TO COMPLETE PRODUCT DEFINITION.
- DIRECTLY-TOLERANCED DIMENSIONS AND BASIC DIMENSIONS DEFINED ON THE DRAWING TAKE PRECEDENCE OVER DIMENSIONAL DATA DEFINED BY THE MODEL. OBTAIN ALL OTHER DIMENSIONAL DATA FROM THE MODEL. THE MODEL REPRESENTS BASIC DIMENSIONAL DATA UNLESS OTHERWISE SPECIFIED.
- APPLICABLE STANDARDS:  
 ASME Y14.41-2003 APPLIES TO DATASET.  
 ASME Y14.5M-1994 APPLIES TO DIMENSIONING AND TOLERANCING.
- $\text{[Symbol]} \text{[Tolerance]} \text{[A]} \text{[B]} \text{[C]}$  APPLIES TO ALL UNTOLERANCED SURFACES.
- FEATURES IDENTIFIED AS STATISTICALLY TOLERANCED ( $\text{[ST]}$ ) SHALL BE PRODUCED WITH STATISTICAL PROCESS CONTROLS OR TO THE MORE RESTRICTIVE ARITHMETIC LIMITS SPECIFIED. DETAILED PROCESS PLAN NEEDED TO COMPLETELY DEFINE STATISTICAL PARAMETERS AND REQUIREMENTS.
- UNITS: INCHES

**PMI Fully-Toleranced Test Case 7 - View A**  
 Includes Atomic Test Cases - 84, 85

Rev D

nist\_ftc\_07\_asme1\_rd

### NIST PMI Test Models - 2014

NOTES (UNLESS OTHERWISE SPECIFIED):

- CAD MODEL \_\_\_\_\_ REV. \_\_\_\_ IS REQUIRED TO COMPLETE PRODUCT DEFINITION.
- DIRECTLY-TOLERANCED DIMENSIONS AND BASIC DIMENSIONS DEFINED ON THE DRAWING TAKE PRECEDENCE OVER DIMENSIONAL DATA DEFINED BY THE MODEL. OBTAIN ALL OTHER DIMENSIONAL DATA FROM THE MODEL. THE MODEL REPRESENTS BASIC DIMENSIONAL DATA UNLESS OTHERWISE SPECIFIED.
- APPLICABLE STANDARDS:  
 ASME Y14.41-2003 APPLIES TO DATASET.  
 ASME Y14.5M-1994 APPLIES TO DIMENSIONING AND TOLERANCING.
- $\square .06 \square A \square B \square C$  APPLIES TO ALL UNTOLERANCED SURFACES.
- DIMENSIONING AND TOLERANCING APPLY WITH PART RESTRAINED AS FOLLOWS, EXCEPT AS INDICATED.  
 PLACE DATUM FEATURE A AGAINST DATUM FEATURE SIMULATOR A.  
 ENGAGE DATUM FEATURES B AND C WITH DATUM FEATURE SIMULATORS B AND C RESPECTIVELY.  
 APPLY LOAD TO PART TO RESTRAIN DATUM FEATURE A AGAINST ITS SIMULATOR.  
 DETAILED INSPECTION PLAN NEEDED TO COMPLETELY DEFINE RESTRAINT.
- UNITS: INCHES

Feature and Specification Index  
**R48J**

PMI Fully-Toleranced Test Case 8 - View A  
Includes Atomic Test Cases - 66, 90

Rev C

nist\_ftc\_08\_asme1\_rc

### NIST PMI Test Models - 2014

NOTES (UNLESS OTHERWISE SPECIFIED):

- CAD MODEL \_\_\_\_\_ REV. \_\_\_\_ IS REQUIRED TO COMPLETE PRODUCT DEFINITION.
- DIRECTLY-TOLERANCED DIMENSIONS AND BASIC DIMENSIONS DEFINED ON THE DRAWING TAKE PRECEDENCE OVER DIMENSIONAL DATA DEFINED BY THE MODEL. OBTAIN ALL OTHER DIMENSIONAL DATA FROM THE MODEL. THE MODEL REPRESENTS BASIC DIMENSIONAL DATA UNLESS OTHERWISE SPECIFIED.
- APPLICABLE STANDARDS:  
 ASME Y14.41-2003 APPLIES TO DATASET.  
 ASME Y14.5M-1994 APPLIES TO DIMENSIONING AND TOLERANCING.
- DIMENSION AND TOLERANCE VALUES SHOWN IN SQUARE BRACKETS [XXX] ARE MILLIMETERS.
- MATERIAL: (.1195 THICK) 11 GA 304 SST SHT, ASTM A240.
- UNITS: INCHES

Feature and Specification Index  
**R48J**

PMI Fully-Toleranced Test Case 9 - View A  
Includes Atomic Test Cases - 59, 61

Rev D

nist\_ftc\_09\_asme1\_rd

### NIST PMI Test Models - 2014

R48J

NOTES (UNLESS OTHERWISE SPECIFIED):

- CAD MODEL \_\_\_\_\_ REV. \_\_\_ IS REQUIRED TO COMPLETE PRODUCT DEFINITION.
- DIRECTLY-TOLERANCED DIMENSIONS AND BASIC DIMENSIONS DEFINED ON THE DRAWING TAKE PRECEDENCE OVER DIMENSIONAL DATA DEFINED BY THE MODEL. OBTAIN ALL OTHER DIMENSIONAL DATA FROM THE MODEL. THE MODEL REPRESENTS BASIC DIMENSIONAL DATA UNLESS OTHERWISE SPECIFIED.
- APPLICABLE STANDARDS:  
 ASME Y14.41-2003 APPLIES TO DATASET AND MOVABLE DATUM TARGETS.  
  
 ASME Y14.5M-1994 APPLIES TO DIMENSIONING AND TOLERANCING.
- FULL DIAMETER OF EACH INDICATED HOLE MUST INTERSECT WITH THE CROSS-DRILLED HOLE AT ITS BOTTOM. INDICATED HOLES MUST NOT CONTACT FAR SIDE OF CROSS-DRILLED HOLES.
- $\text{1.5} \text{ [A] [B] [C]}$  APPLIES TO ALL UNTOLERANCED SURFACES.
- UNITS: MILLIMETERS

**PMI Fully-Toleranced Test Case 10 - View A**  
 Includes Atomic Test Cases - N/A

Rev B

nist\_ftc\_10\_asme1\_rb

### NIST PMI Test Models - 2014

Feature and Specification Index  
[nist\\_ftc\\_11\\_asme1\\_rb\\_fsi.pdf](#)

NOTES (UNLESS OTHERWISE SPECIFIED):

- CAD MODEL \_\_\_\_\_ REV. \_\_\_ IS REQUIRED TO COMPLETE PRODUCT DEFINITION.
- DIRECTLY-TOLERANCED DIMENSIONS AND BASIC DIMENSIONS DEFINED ON THE DRAWING TAKE PRECEDENCE OVER DIMENSIONAL DATA DEFINED BY THE MODEL. OBTAIN ALL OTHER DIMENSIONAL DATA FROM THE MODEL. THE MODEL REPRESENTS BASIC DIMENSIONAL DATA UNLESS OTHERWISE SPECIFIED.
- APPLICABLE STANDARDS:  
 ASME Y14.41-2003 APPLIES TO DATASET.  
  
 ASME Y14.5M-1994 APPLIES TO DIMENSIONING AND TOLERANCING.
- NON-RIGID PART. DIRECTLY-TOLERANCED DIMENSIONS AND TOLERANCES APPLY IN FREE STATE.
- UNITS: MILLIMETERS

**PMI Fully-Toleranced Test Case 11 - View A**  
 Includes Atomic Test Cases - 55, 100

Rev B

nist\_ftc\_11\_asme1\_rb