



**Test Suite for the
CAx Interoperability Forum
Round 46J**

March – September 2020

Release 1.2

12 August 2020

Contacts

Jochen Boy
PROSTEP AG
Dolivostraße 11
64293 Darmstadt / Germany
jochen.boy@prostep.com

Jean-Marc Crepel
AFNeT
30, Rue de Miromesnil
75008 Paris / France
jean-marc.crepel@afnet.fr

Phil Rosché
ACCR, LLC.
125 King Charles Circle
Summerville, SC 29485 USA
phil.rosche@accr-llc.com

Table of Contents

1	Introduction	3
1.1	Functionality tested in this round	4
1.2	General testing instructions for this round.....	4
1.3	Testing Schedule.....	5
1.4	Copyrights on Test Cases	5
2	Synthetic Test Case Specifications	6
2.1	Test Case SP7: Semantic PMI Representation	6
2.2	Test Case TGP3: 3D Tessellated Geometry & Tessellated PMI Presentation	10
2.3	Test Case PDM6: AP242 BO Model XML PDM Interoperability.....	14
2.4	Test Case KM1: Kinematics.....	15
2.5	Test Case CO2: Composite Materials (Ply Contour).....	18
2.6	Test Case CO3: Composite Materials (3D Explicit Ply Representation).....	21
2.7	Test Case PID: Persistent IDs	23
Annex A	NIST Model Translation Configuration Considerations	29
Annex B	NIST Model Definitions	31
Annex C	Composite Data model for Rosette Type 2	37

List of Figures

Figure 1:	CAx-IF Round46J Schedule	5
Figure 2:	Illustration of the KM1 test models.....	16
Figure 3:	Illustration of the CO2 Test Case.....	18
Figure 4:	Illustration of the CO3 Test Case.....	21
Figure 5:	NIST FTC09, View C, slotted hole.....	26
Figure 6:	NIST Test Case FTC09, View A, Detail of Hole	26
Figure 7:	NIST Test Case FTC09, View C, Detail of Slotted Hole	27
Figure 8:	NX 8 vs. NX 9 Dimension Display Names	30
Figure 9:	ASME_Y14.37_RosetteType2.CATPart	37
Figure 10:	Old Recommendation from AP203e2	37
Figure 11:	New Recommendations AP242 E2.....	38

Document History

Release	Date	Change
1.0	2020-05-28	Initial Release
1.1	2020-06-10	Updated references to Recommended Practices
1.2	2020-08-12	Update of Kinematics Test Case

1 Introduction

The CAx Interoperability Forum (CAx-IF) is part of the Model-Based Interoperability Forum (MBx-IF), which is a joint effort between AFNeT, PDES, Inc. and prostep ivip. An interoperability forum is a logical collection of a user group and an implementer group, focused on specific capabilities of a named standard, in this case ISO 10303 STEP.

- The **User Group** is comprised of industry representatives, all members of at least one of the Interoperability Forum hosting organizations. The group will define and prioritize use cases, derive requirements and related validation properties as well as document user best practices.
- The **Implementor Group** is a group of software vendors, 3rd party integrators, and independent implementors, all members of at least one of the Interoperability Forum hosting organizations, that define recommended practices based on the prioritized use cases provided by the user group and validate them in test rounds.

The objectives of the CAx-IF concentrate primarily on testing the interoperability and compliance of STEP processors based on AP242 Ed. 1 & 2 and include documenting and prioritizing use cases, requirements and best practices to ensure completeness and consistency of the STEP standard and its implementations, implementing new functionalities based on users' requirements while ensuring these do not adversely affect existing implementations, avoiding roadblocks by establishing agreed-upon approaches, and increasing user confidence in STEP by providing interoperable commercial software products.

The CAx-IF's Implementor Group performs two test rounds per year for each domain and present summary results to the user community. Furthermore, Recommended Practices are developed, and issues are reported to the standards development community.

The test rounds in general combine testing of synthetic and production models. Production models will in most cases be provided by the user companies of the organizations AFNeT, PDES, Inc., and prostep ivip Association. When production models are not available from the user companies, "production-like" models will be solicited from the various CAx-IF participants.

This test suite includes synthetic models for testing the following capabilities: Product Manufacturing Information (PMI), both as Graphic Presentation and as Semantic Representation, 3D Tessellated Geometry, Kinematics, and Assembly Structure with External References in AP242 BO Model XML format.

1.1 *Functionality tested in this round*

Functionality tested in this round relates to:

- **Product Manufacturing Information (PMI)** describes the capability to embed information about dimensions, tolerances and other parameters which are necessary input for the manufacturing and measuring of the part from the 3D model. This round, the focus will be on the two approaches for the transfer of PMI in the 3D model:
 - “Tessellated Presentation” refers to breaking down each annotation into tessellated elements as supported by AP242 and exchanging them as geometry. This preserves the exact shape of the annotation but is human readable only. The test will include section views as well.
 - “Semantic Representation” refers to the intelligent transfer of PMI data in an associative and reusable way. This scenario aims towards driving downstream usage and later modifications of the model. The data is machine-readable, but not necessarily visible in the 3D model. The test also includes additional presentation data, which can be linked to the corresponding PMI representation.
- **Tessellated Geometry** is a simplified representation for the part shape, where the geometry is not given as an exact B-Rep model, but as a collection of simple planar faces (triangles) which can be easily and efficiently created and applied in specific use cases. The scope includes watertight tessellation and compressed STEP files.
- **AP242 BO Model XML Assembly Structure** is an implementation format introduced with AP242, and the designated process format for many applications in the aerospace and automotive industries. It will be used in combination with geometry formats matching the respective requirement. In the CAX-IF, the geometry files will be in STEP Part 21 format. The XML files contain the assembly structure and part master information. The tests, which are conducted jointly with the PDM-IF, primarily aim at improving CAX-PDM interoperability by ensuring that the different types of systems correctly cope with the different levels of information.
- **Composite Materials** are made by layering various plies of material on top of each other. They can be defined in an implicit-precise way, by giving the laminate tables, ply boundaries, orientation, materials, and laminated cores; or in an explicit-tessellated way by calculating the resulting 3D Tessellated Solid. Both representations can be linked to each other.
- **Kinematics** is a capability in AP242 that allows describing the motion of parts over time and in relation to each other. This includes the definition of mechanisms with joints and constraints, defining the kinematic relationships between the parts, as well as motions, which are defined by capturing the positions of the moving parts at discrete points in time. In order to cover Aerospace as well as Automotive use cases, and to increase the range of participating systems, this capability is being tested jointly with the JT-IF.
- **Persistent Entity IDs** enable the ability to track a product’s model information during design iteration, and from design iteration through to manufacturing and quality analysis. This will allow downstream systems to update their representations of the design model and update their manufacturing and metrology planning to reflect changes in the design.

1.2 *General testing instructions for this round*

The general procedures for communication of models and statistics are outlined in a separate document, named ‘General Testing Instructions’. The document can be retrieved from the CAX Interoperability Forum web sites. The latest version is v1.13, dated September 29, 2017.

1.3 Testing Schedule

The following schedule has been agreed upon for Round 46J:

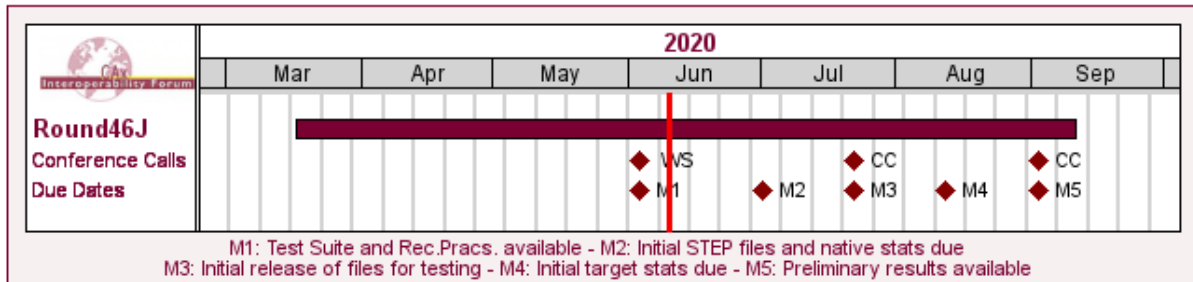

Date	Action
3 Jun 2020 (Wed)	CAX-IF Round 46J Kick-Off Meeting in Cyberspace / Test Suite and Rec.Pracs. available
1 Jul 2020 (Wed)	Initial STEP files and native stats due
22 Jul 2020 (Wed)	1st CAX-IF Round46J Conference Call / Initial release of files for testing
12 Aug 2020 (Wed)	Initial target stats due
2 Sep 2020 (Wed)	2nd CAX-IF Round46J Conference Call / Preliminary results available
8 Sep 2020 (Tue) - 10 Sep 2020 (Thu)	CAX-IF Round46J Review Meeting in Cyberspace

Figure 1: CAX-IF Round46J Schedule

The CAX-IF Round 46J Review meeting will take place in conjunction with a LOTAR workshop. Considering the continuing travel restrictions in the wake of COVID-19, the September meeting will be conducted fully online.

1.4 Copyrights on Test Cases

1.4.1 CAX-IF

None of the production test cases which were provided by the AFNeT, PDES, Inc. and prostep ivip member companies may be publicly released for any purpose. The test cases can be freely distributed among the CAX-IF members and can be used for any purposes that are related to CAX-IF testing (i.e. testing, documentation of testing efforts, etc.), if a reference to the originating company is made.

The test cases must not be used for any purposes other than CAX-IF testing or outside of AFNeT, PDES, Inc. and prostep ivip. Test cases provided by the LOTAR project for testing of specific capabilities are applicable to the same restrictions and may not be used outside LOTAR or the CAX-IF.

1.4.2 NIST

The test cases developed at the National Institute of Standards and Technology (NIST) are not subject to copyright protection and are in the public domain. NIST assumes no responsibility for the components of the test system for use by other parties and makes no guarantees, expressed or implied, about their quality, reliability, or any other characteristic. The use of the CAD systems to create the Test Models does not imply a recommendation or endorsement by NIST.

For more details, read the disclaimer at <http://go.usa.gov/mGVm>

2 Synthetic Test Case Specifications

2.1 Test Case SP7: Semantic PMI Representation

All information about this test case can also be viewed in CAESAR on its Information page.

2.1.1 Motivation

Product Manufacturing Information (PMI) is required for a number of business use cases in the context of STEP data exchange. Among others, it is a prerequisite for long-term data archiving. In addition, PMI can be used to drive downstream applications such as coordinate measuring and manufacturing.

Semantic PMI Representation relates to the capability to store PMI data in the STEP file in a computer-interpretable way, so that it can be used for model redesign or downstream applications. Though the definition of the data is complete, it is by itself not visible in the 3D model.

Additional presentation capabilities are needed to display the data in a way that it is visible to the user in the 3D model. The presentation data will not be formally evaluated in the SP7 test case, as this is the scope of the TGP3 test case (see section 2.2).

A wide variety of test models is available from NIST as well as prostep ivip, each containing a different selection of PMI elements. In the past, the overall success of PMI transfer was evaluated. In Round 46J, a focus scope will be defined for each model, and evaluation of the tests will concentrate on the characteristics of these particular PMI elements.

2.1.2 Approach

The approach to be used is described in the latest version (at least v4.0.7, dated 28 May 2020) of the “Recommended Practices for Representation and Presentation of PMI (AP242)”, which can be found in the CAX-IF member area under “Information on Round46J of Testing”.

Within the PMI domain, the following functionalities are in scope of Round 46J:

- Semantic PMI Representation
- Graphic PMI Presentation (Polyline or Tessellated)
- Correct implementation and definition of the Saved Views (view layout and contents)
- Linking of PMI Representation to Presentation
- Transfer of editable PMI text as User Defined Attributes
- Semantic PMI Representation Validation Properties

The AP242 schema to be used is the AP242 Edition 2 IS schema, which is available on the CAX-IF homepages under “Public Testing Information”. Note that this is the same schema that was previously stored in the member area as AP242 Ed. 2 DIS schema; there have been no changes for the final publication.

Pre-checking of files with SFA: All vendors generating STEP files for the SP7 test case shall run them through the latest version of NIST’s STEP File Analyzer and Viewer (SFA; currently version 4.14). The tool provides feedback on basic syntax errors such as missing or malformed entity instances. Files with such errors will not be accepted for testing.

SFA can be downloaded for free at <https://go.usa.gov/yccx/>

2.1.3 Testing Instructions

The tests will be performed based on a verified set of test models, each with set of well-defined PMI elements. In Round 46J, the models developed in the context of the “MBE PMI Validation and Conformance Testing” project will be used again, as they have been designed with emphasis on particular PMI capabilities.

2.1.3.1 NIST Test Model Overview

The NIST models are constantly updated to the latest CAD software releases by the respective system vendors, in order to improve the definition of the models using the latest CAD system capabilities.

The links to the test model definitions, the NIST web page for the MBE PMI Validation and Conformance Testing Project, and illustrations of the 11 test cases can be found at the end of this document in Annex B.

2.1.3.2 NIST Test Model Access

The updated native CAD files can be downloaded using the hyperlinks in the list below:

- [CATIA V5-6R2019](#) (all CTC and all FTC models)
- [Creo 4](#) (all CTC and all FTC models)
- [NX12](#) (all CTC and all FTC models)
- [SolidWorks MBD 2018](#) (all CTC and all FTC models)
- [Inventor 2019](#) (all CTC and all FTC models)

Even though many updates have already been made by the respective system vendors, a number of verification issues remain to be solved. Should new native models with further updates become available during the test round, they will be distributed and announced accordingly.

2.1.3.3 NIST Test Model Selection

A subset of the NIST test cases has been selected for Round 46J. Furthermore, for each test case, specific focus capabilities have been defined which will be the main objective for test evaluation this round:

- **CTC-2:** Datum Targets (points), Hole feature for multiple holes
- **CTC-3:** Tolerances of various types (flatness, position, profile...)
- **CTC-5:** Datum targets (rectangular), spherical diameter, good mix of geometric tolerances and modifiers
- **FTC-6:** Datum targets (lines and curves), radius, more holes
- **FTC-8:** Complex and stacked feature control frames, mix of tolerances and modifiers

Note that this list has two changes compared to previous rounds of testing: CTC-3 instead of CTC-4, and FTC-8 instead of FTC-9.

Note that vendors are encouraged to submit STEP files for all 11 NIST test cases, for investigation by Bob Lipman. However, only STEP files for the five models listed above will be distributed for testing in Round 46J and their respective results evaluated on CAESAR.

2.1.4 Test Model Configuration

The following functionality shall be included in the test files provided for this round of testing, as far as it has been implemented by the CAX-IF participants and is described in the Recommended Practices:

- **PMI Representation** – the re-usable representation of PMI data should be included in all SP7 models to the extent supported by the native system.
- **PMI Graphic Presentation** – Many CAD systems require some minimal presentation information to be able to handle the PMI data in a model. Usually, both PMI representation and presentation data are included in the same file. Thus, some form of presentation information shall be included in the SP7 test case as well.

- **Definition of “Saved Views”** – as far as supported, include the saved views defined in the models, which contain a subset of annotations in the file, and provide a pre-defined position of the model in the design space.
 - All models have multiple Saved Views defined. In the test case definition documents, each page of the PDF document represents one Saved View.
 - For each view, a screenshot showing the model layout (displayed elements, orientation, zoom) shall be provided.

Note that it is possible to attach several screenshots to one set of statistics in CAESAR. The name of the view shall be given as description for the screenshot.

 - Both “basic” and “advanced” view implementations are allowed.
 - The Saved Views shall also correctly show (or hide) the part geometry, as well as the non-solid Supplemental Geometry contained in some of the models (see section 9.4.2 / Figure 93 in the PMI Rec. Practices v4.0.7. An additional document pointing out important supplemental geometry elements for the NIST test cases is available in the CAx-IF member area, under “Information on Round 42J of testing”).
- **Editable PMI Text** – Some information relevant for PMI is not encoded in semantic entities, but given as plain text, such as the title block information or additional text on feature control frames. In the context of semantic data exchange, this content needs to be editable in the target system. The approach to be used for this is based on the transfer of User Defined Attributes, and its application in the context of PMI is described in section 7.4 of the PMI Recommended Practices v4.0.7.
- **Linking PMI Representation to Presentation** – If a model contains PMI Representation information as well as Presentation data, the corresponding elements shall be linked together, so that a Representation element “knows” which annotation it is being presented in the model. The approach to create this link is described in section 7.3 of the PMI Rec. Pracs. (v4.0.7).
- **Validation Properties** – All participants providing STEP files for this test case are encouraged to include validation properties as far as supported. In particular, for vendors already working on the topic, validation properties for Semantic PMI Representation should be included in the test files, based on section 10.1 in the PMI Recommended Practices v4.0.7.

Also refer to Annex A for test model translation configuration considerations.

2.1.5 Statistics

For each STEP file exported or imported for the SP7 test case, vendors must submit the corresponding statistics. To do so, go to the [SP7 Data Sheet], and either fill in the web form, or upload a comma-delimited file (.csv) with the data as listed below.

Native Statistics

When exporting a STEP file, report what data importing systems should expect to find. For numeric statistics, enter the respective value or 'na' if not supported. For other statistics, select either 'full support' (i.e. test case and Rec. Pracs. definitions are fulfilled), 'limited support' (meaning the implementation does not meet all criteria and issues may be expected on import), or 'na' if not supported.

Target Statistics

When importing a STEP file, report the results after processing the file as described below.

Screenshots

If presentation information is contained in the test files, it shall be accompanied by corresponding screenshots. Note that CAESAR allows the addition of multiple screenshots per dataset.

Note that in order to count the GD&T elements for the statistics, per agreement during the R22J Review Meeting, the actual STEP entity types (`datum`, `datum_target`...) shall be considered.

Note that based on the Round 35J results, a new count has been added for Composite Tolerances as defined in section 6.9.9. of the PMI Rec. Pracs. (v4.0.7).

Note that all statistics – native and target – shall be based on the Semantic PMI Representation data only, and not take any presentation into account.

Note that for evaluation, the spreadsheets generated by the STEP File Analyzer and Viewer will be amended with corresponding aggregations of relevant counts and charts.

Data Sheet Columns

column name	description
model	The name of the test model, here 'sp7', with one of the following suffixed: 02, 04, 05, 06, 09.
system_n	The system code of the CAD system creating the STEP file
system_t	The system code of the CAD system importing the STEP file. For native stats, select 'stp'
scope	A short designation for the contents of the model as defined in the Test Suite. This is for information only; there will be no results for this field.
dimensions	The number of dimensions processed
datums	The number of datums processed
datum_targets	The number of datum targets processed
tolerances	The number of tolerances (all types combined) processed, regardless of composition.
compos_tols	The number of composite tolerances processed (number of instances of <code>geometric_tolerance_relationship</code> per section 6.9.9. in the PMI Rec. Pracs. v4.0).
labels	The number of labels processed
pmi_semantic_txt	all/partial/none – whether 'semantic' (editable) PMI text was transferred correctly (content and associativity)
pmi_semantic_val-prop	all/partial/none – whether the validation properties for Semantic PMI Representation matched for all, some or none of the semantic PMI elements.
saved_view	The name of the Saved View which is the basis for the view-related statistics
view_annot	The number of annotations included in the specified saved view.
view_pos	pass/fail, whether the model orientation and zoom factor stored for the Saved View could be restored successfully.
elem_visibility	all/partial/none – whether all, some, or none of the elements to be displayed in the indicated saved view were mapped correctly into the corresponding <code>draughting_model</code> .
pmi_graphic_pres	all/partial/none – whether the graphic PMI annotations included in the file could be processed correctly
pmi_present_val-prop	all/partial/none – whether the validation properties for Graphic PMI Presentation matched for all, some or none of the presentation elements.

column name	description
pmi_linked_pres_rep	all/partial/none – whether the Semantic PMI Representation elements and (Graphic) PMI Presentation elements were linked correctly together.
date	The date when the statistics were last updated (will be filled in automatically)
issues	A short statement on issues with the file

2.2 Test Case TGP3: 3D Tessellated Geometry & Tessellated PMI Presentation

All information about this test case can also be viewed in CAESAR on its Information page.

2.2.1 Motivation

In addition to use cases that require a fully defined, precise, semantic definition of the part geometry and associated PMI, as is the focus of the SP7 test case described above, there are also scenarios where the presentation of the data – geometry and annotations – for visual consumption are the primary goal. In such cases, a simplified and optimized version of the model is sufficient.

For this purpose, AP242 introduced a data model for tessellated geometry, which can be used for tessellated part geometry, and also for graphic presentation of PMI in a much more efficient way than was the case with Polylines – especially in the case of filled characters. Tessellated PMI Presentation has been tested in combination with precise B-Rep geometry during previous test rounds; in Round 46J, the focus is a pure visualization scenario, where the part shape as well as the graphic PMI are given as tessellated geometry.

2.2.2 Approach

The approach to be used for Tessellated PMI Presentation is described in the latest version (at least v4.0.7, dated 28 May 2020) of the “Recommended Practices for Representation and Presentation of PMI (AP242)”, which can be found in the CAX-IF member area under “Information on Round46J of Testing”.

The approach to be used for the definition of the part shape is defined in the “Recommended Practices for Tessellated 3D Geometry” (v1.1; 22 August 2019), available on the public CAX-IF web sites under “Public Testing Information”.

The preferred AP242 schema to be used is the AP242 Edition 2 IS schema, which can be found on the public CAX-IF web sites under “Public Testing Information”. As a fallback, the AP242 Edition 1 IS version can be used.

Pre-checking of files with SFA: All vendors generating STEP files for the TGP3 test case shall run them through the latest version of NIST’s STEP File Analyzer and Viewer (SFA; currently version 4.14). The tool provides feedback on basic syntax errors such as missing or malformed entity instances. Files with such errors will not be accepted for testing.

SFA can be downloaded for free at <https://go.usa.gov/yccx/>.

2.2.3 Testing Instructions

The tests will be performed based on a subset of the NIST test models; see test case SP7 for details.

2.2.3.1 Test Model Overview

- See section 2.1.3.1 above, as well as Annex B.

2.2.3.2 Test Model Access.

- See section 2.1.3.2 above.

2.2.3.3 Test Model Selection

In order to reduce the workload for the participating vendors, not all eleven models shall be tested in Round 46J. The following five models have chosen:

- CTC 2, 3 & 5
- FTC 6 & 8

This selection still covers a wide range of PMI elements, while reducing the number of exchanges to be done for each interface vendor.

Note that this list has changed compared to previous rounds of testing and uses CTC-3 instead of FTC-9. This is aligned with the model selection for the SP7 test case.

Note that vendors are encouraged to submit STEP files for all 11 NIST test cases, for investigation by Bob Lipman. However, only STEP files for the five models listed above will be distributed for testing in Round 46J and their respective results evaluated on CAESAR.

2.2.3.4 Test Model Configuration

The following functionality shall be included in the test files provided for this round of testing, as far as it has been implemented by the CAX-IF participants and is described in the respective Recommended Practices:

- Tessellated 3D Geometry – include the part shape as tessellated geometry. If supported, water-tight tessellation shall be used. B-Rep geometry will be accepted only if Tessellated Geometry isn't supported at all on export.
- Tessellated Presentation – include the PMI elements as tessellated annotations. Stroked, outline, and filled fonts (and combinations) are allowed, as well as styling of the annotations (colors).
- Definition of "Saved Views" – as far as supported, include the saved views defined in the models, which contain a subset of annotations in the file, and provide a pre-defined position of the model in the design space.

- All models have multiple Saved Views defined. In the test case definition documents, each page of the PDF document represents one Saved View.
- For each view, a screenshot showing the model layout (displayed elements, orientation, zoom) shall be provided.

Note that it is possible to attach several screenshots to one set of statistics in CAESAR. The name of the view shall be given as description for the screenshot.

- Both "basic" and "advanced" view implementations are allowed.
- The Saved Views also shall correctly show (or hide) the part geometry, as well as the non-solid Supplemental Geometry contained in some of the models (see section 9.4.2 / Figure 93 in the PMI Rec. Practices v4.0.7). An additional document pointing out important supplemental geometry elements for the NIST test cases is available in the CAX-IF member area, under "Information on Round 42J of testing".
- Cross-highlighting of annotations and annotated shape – if supported, include in the STEP file the information necessary to maintain the association between annotations and the annotated shape elements in a way, that after import, when highlighting an annotation, the shape elements annotated by it are highlighted too, and vice versa.

- Validation Properties for Tessellated Geometry and Presentation – as far as supported and applicable, include validation properties for tessellated 3D geometry as well as tessellated PMI presentations, making sure they are associated with the correct target elements and do not interfere with each other, and evaluate these after import.

Also refer to Annex A for test model translation configuration considerations.

Note that for the creation of the Equivalent Unicode String, the mapping as defined by the “Unicode String Project” report (Revision J) shall be used. This document is available on the public CAX-IF homepages, under “Joint Testing Information”.

Note that for the PMI validation properties, the new optimized implementation structure for validation properties can be used. This is currently defined in section 4.12 of the “Recommended Practices for Geometric and Assembly Validation Properties” (v4.5, dated 22 August 2019), which can be found on the CAX-IF homepages, under “Public Testing Information”.

2.2.3.5 Statistics

For each STEP file exported or imported for the TGP3 test case, vendors must submit the corresponding statistics to CAESAR. To do so, go to the [TGP3 Data Sheet], and either fill in the web form, or upload a comma-delimited file (.csv) with the data as listed below.

View-related Statistics

Several of the Statistics for this test case are view-related (e.g. number of annotations, positioning/scaling). The statistics cannot evaluate this for all views in the model. Hence, the idea is to select one specific (interesting) view on export and publish its name in the “Saved View” field of the statistics. It is recommended to use the first view (by name, alphabetized) in the model. Then, fill in the other view-related statistics with the values as valid for this particular view. After import, select the view with the name given in the native statistics and again provide the values valid for this view.

Native Statistics

When exporting a STEP file, report what data importing systems should expect to find. For numeric statistics, enter the respective value or 'na' if not supported. For other statistics, select either 'full support' (i.e. test case and Rec. Pracs. definitions are fulfilled), 'limited support' (meaning the implementation does not meet all criteria and issues may be expected on import), or 'na' if not supported.

Target Statistics

When importing a STEP file, report the results found after processing the file as described in the table below.

Screenshots

For each Saved View in the model, provide one screenshot, which illustrates the layout (displayed geometry and annotation, model orientation, and zoom factor). Give the name of the view as the description of the screenshot.

Note that in order to count the PMI elements for the statistics, per agreement during the Round 22J Review Meeting, the names of the `tessellated_geometric_set` shall be considered.

See section “Indicating the Presented PMI Type” in the PMI Rec. Practices for details.

Data Sheet Columns

column name	Description
model	The name of the test model, here: 'TGP3' followed by the model index; e.g. 'TGP3-03'.
system_n	The system code of the CAD system creating the STEP file
system_t	The system code of the CAD system importing the STEP file. For native stats, enter 'stp'
dimension	The number of dimensions processed
datums	The number of datums processed
datum_targets	The number of datum targets processed
tolerances	The number of tolerances processed
labels	The number of labels processed
saved_view	The name of the Saved View which is the basis for the view-related statistics
view_annot	The number of annotations included in the specified saved view.
view_pos	pass/fail, whether the model orientation and zoom factor stored for the Saved View could be restored successfully.
elem_visibility	all/partial/none – whether all, some, or none of the elements to be displayed in the indicated saved view were mapped correctly into the corresponding draughting_model.
highlight	all/partial/none – whether the cross-highlighting for annotations and annotated shape elements works correctly
tess_pmi_area	all/partial/none – whether the surface area of the Tessellated PMI annotations was validated successfully for all, some or none of the given annotations.
tess_pmi_clength	all/partial/none – whether the total length of segments per Tessellated PMI annotation was validated successfully for all, some or none of the given annotations.
tess_pmi_c	all/partial/none – whether the centroids of the Tessellated PMI annotations were validated successfully for all, some or none of the given annotations.
eq_unicode	all/partial/none - if the encoding of the equivalent Unicode string was correct for all, some or none of the given annotations.
valid_tess_vp	pass/fail, is the instantiation of the validation properties for Tessellated Geometry in the STEP file per the recommended practices?
affected_geo	all/partial/none – whether the affected geometry could be validated correctly for all, some or none of the PMI statements in the model.
date	The date when the statistics were last updated (will be filled in automatically)
issues	A short statement on issues with the file

2.3 Test Case PDM6: AP242 BO Model XML PDM Interoperability

All information about this test case can also be viewed in CAESAR on its Information page.

2.3.1 Motivation

The AP242 BO Model XML is the designated standard process format for the automotive and aerospace industries. As such, it is being used in a variety of use cases. One of its main application scenarios is the exchange of Product Data Management (PDM) information. To develop the specific capabilities needed for this, the PDM-IF has been launched, and has just concluded its sixth round of testing.

The Recommended Practices for AP242 BO Model XML Product & Assembly Structure are a joint publication of the PDM-IF with the CAX-IF and the JT-IF.

CAX-PDM Interoperability has been tested in previous rounds of the CAX-IF and PDM-IF testing and led to improvements in the Recommended Practices as well as the participating interfaces. The PDM-IF has identified OEM-Supplier collaboration as a test case within its “Visual Issue Management” use case. This represents the scenario where an OEM with a sophisticated PLM landscape works together with a smaller supplier who uses the CAD system directly. For these tests, the PDM-IF takes on the role of the customer while the CAX-IF acts as the Supplier.

Other use cases of the PDM-IF cover capabilities such as Configuration Management or Multi-View Product Structures (“as designed” / “as planned”). While CAD systems are not required to handle this kind of information, they need to find their way around it in order to retrieve the underlying component data.

2.3.2 Approach

The following schemas and documents shall be used for this test:

- AP242 Business Object Model XML – for schema location, see the corresponding Rec. Practices listed below.
- Recommended Practices for AP242 (TC) Business Object Model XML Assembly Structure, version 2.1, dated December 20, 2019, which is available from the public CAX-IF homepage under “Implementor Group → CAX Recommended Practices”.
 - Section 16 “CAX-PDM Interoperability Guide” within this document covers recommendations for the handling of multiple part IDs and multiple languages.
- AP242 Edition 1 or Edition 2 Longform EXPRESS schema for the geometry files.

Unless otherwise noted, all documents are available on the homepage of the CAX-IF Implementor Group.

2.3.3 Testing Instructions

Like many other projects, the PDM-IF schedule has been affected by COVID-19. Due to the measures taken to slow down the spread of the pandemic, many experts were temporarily unavailable, so that the current test round 10, which was scheduled to end mid of June, will be extended until the end of August.

If and when AP242 XML file sets will be released by the PDM-IF for testing by the CAX-IF, they will be made available in the CAX-IF member area, and the details of this test case will be filled in depending on the scope of the provided files.

2.4 Test Case KM1: Kinematics

All information about this test case can also be viewed in CAESAR on its Information page.

2.4.1 Motivation

CAD methods have been used for many years now to design individual parts and assemblies of all sizes across all industries, from a single rivet to an entire airplane. Classically, the main focus is to ensure that the part can be manufactured correctly.

Products such as cars or planes are not static, however, contain many moving components: engine, power windows, foldable roof, windshield wipers, cargo doors, etc. Thus, Kinematics are used to ensure they move correctly, as well as to illustrate the behavior of the finished product. The use cases range from the definition of the Kinematic Mechanism, providing all relationships and constraints between the elements so that their definition can be changed in the receiving application, to Kinematic Motion, which works like a movie by providing discrete positions of the components over time.

The goal is to use a neutral standard format – AP242 BO Model XML – for the definition of the Kinematic mechanisms and motion, with external references to the applicable geometry format for the respective use case.

2.4.2 Approach

The approaches for “Kinematic Mechanism” and “Kinematic Motion” are described in the “Recommended Practices for STEP AP242 TC Business Object Model XML Kinematics”, Version 0.10 (dated August 26, 2019), which can be found in the CAD member area of the CAX-IF web sites under “Information on Round 44J of Testing”.

During the development of these capabilities, several new entity types have been defined to improve the implementation structure. This will be included in AP242 with the DIS release of Edition 2. To enable immediate testing, a trial XSD schema is available, which is built by extending the AP242 TC schema with these new entities. It is available at the following URL:

https://www.cax-if.de/xml-schema/3001/20170810/bom_20170810.xsd

The corresponding name space definition is given in the aforementioned Recommended Practices, Section 1.1.2.

The Kinematic capabilities for AP242 XML are developed jointly by the CAX-IF and the JT-IF, thus supporting Aerospace as well as Automotive requirements, and also broadening the scope of participating STEP translators. To ease the exchange of the files, the part geometry files for the KM1 test model are available in STEP AP242 Part 21 as well as ISO JT (JT v9.5) format, so the AP242 XML file references can easily be adapted for the preferred geometry format.

Based on this approach, Kinematic test files...

- ...from JT-IF Round 19 (February – June 2020) will be fed into CAX-IF Round 46J. Details on the provided files will be added to an updated revision of this document.
- ...from CAX-IF Round 46J will be passed on to JT-IF Round 21 (August – November 2020)

The following files have been provided by the JT-IF:

Model	CAD System	Translator	Scope
km1-ct5	CATIA V5	CT CoreTechnologie 3D_Evolution	Kin. Mechanism
km1-cto	Creo	CT CoreTechnologie 3D_Evolution	Kin. Mechanism
km1-ctx	NX	CT CoreTechnologie 3D_Evolution	Kin. Mechanism

2.4.3 Testing Instructions

A set of sample models is provided for the Kinematics tests. The mechanism can best be described as a single-cylinder piston engine. The model is available in the following native formats:

- CATIA V5R21
- Creo 3.0
- NX 11

The files can be found in the File Repository inside the CAX-IF member area, in the folder “/CAD/Round 41J/Kinematics”.

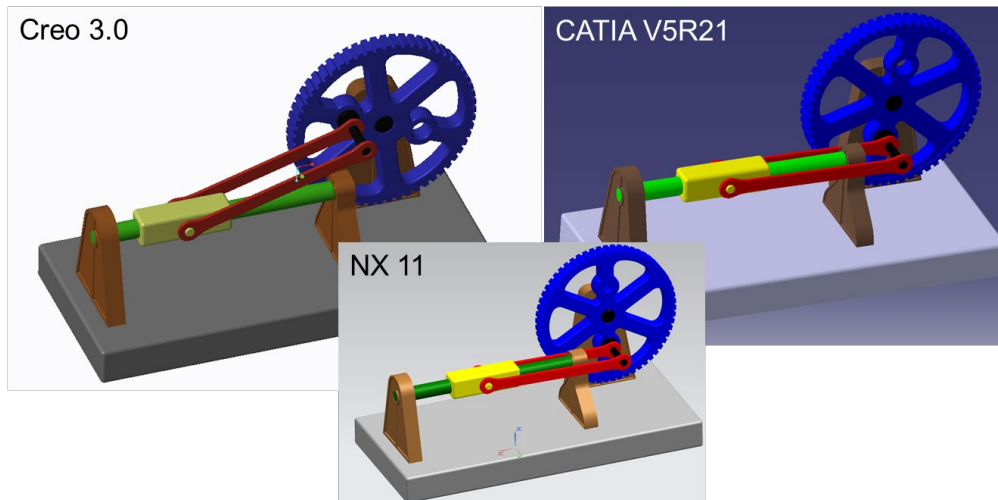

Figure 2: Illustration of the KM1 test models

The following is in scope of Round 46J:

- Kinematic Motion provides discrete positions of the moving components with a time index and can be played back similar to a stop-motion animation. This capability is aimed mostly at viewing and long-term archiving scenarios, because it does not require the target application to have a kinematic solver.
- Kinematic Mechanism includes the definition of kinematic pairs (joints and constraints) and actuators. The goal is that the mechanism is editable in the target system, while preserving the dependencies defined in the original system.
- Assembly & Kinematic Data shall be provided in a single AP242 BO Model XML file.
- Geometry shall be included as STEP AP242 Part 21 precise B-Rep files.

Note that the Kinematic capabilities (Mechanism as well as Motion) are tested in cooperation with the JT Implementor Forum, in order to increase the number of participating systems and to enable exchange of data between different systems. This requires replacing the geometry files as well as the file references in the AP242 XML file but has no impact on the actual Kinematic capabilities.

2.4.4 Statistics

For each STEP file exported or imported for the KM1 test case, vendors must submit the corresponding statistics. To do so, go to the [KM1 Data Sheet], and either fill in the web form, or upload a comma-delimited file (.csv) with the data as listed below.

Native Statistics

When exporting a STEP file, report what data importing systems should expect to find. For numeric statistics, enter the respective value or 'na' if not supported. For other statistics, select 'full support' (i.e. test case and Rec. Pracs. definitions are fulfilled), 'limited support' (meaning the implementation does not meet all criteria and issues may be expected on import), or 'na' if not supported.

Target Statistics

When importing a file, report the results found after processing the file as described below.

Kinematics-specific Statistics

For more detailed information about and discussion of in the Kinematics-specific statistics, please refer to section 4.12 of the Kinematics Recommended Practices mentioned above.

Data Sheet Columns

column name	description
model	The name of the test model, here 'SM2'
system_n	The system code of the CAD system creating the STEP file
system_t	The system code of the CAD system importing the STEP file. For native stats, select 'stp'
assem_struct	pass/fail – if the model structure (assembly tree) was transferred correctly, i.e. no nodes have been added or removed, and all elements are on the correct hierarchical level.
Kin_motions	The number of Kinematic Motions defined in the model
kin_motion_paths	The number of paths defined for a Kinematic Motion
kin_mechanisms	The number of Kinematic Mechanisms defined in the model
kin_mech_pairs	The number of low/high order Kinematic Pairs defined for a Kinematic Mechanism
kin_revolute_pairs	The number of Revolute Pairs defined for Kinematic Mechanisms
kin_cylindrical_pairs	The number of Cylindrical Pairs defined for Kinematic Mechanisms
kin_planar_pairs	The number of Planar Pairs defined for Kinematic Mechanisms
kin_mech_acts	The number of Kinematic Pairs that have a non-zero value in the attribute 'actuation', i.e. where an initial movement can occur
date	The date when the statistics were last updated (will be filled in automatically)
issues	A short statement on issues with the file

2.5 Test Case CO2: Composite Materials (Ply Contour)

All information about this test case can also be viewed in CAESAR on its Information page.

2.5.1 Motivation

For several years, some STEP composite interfaces have been available in several CAD tools such as CATIA V5, FiberSIM and in CT CoreTechnologie tools, with a certain level of maturity proven by LOTAR pilot projects.

The goal of including Composite Materials in a CAX-IF test round is to align these implementations and provide an official framework for composite materials implementation tests as STEP AP 242e1 since it includes this capability.

2.5.2 Approach

The scope of this test case is the “exact implicit” representation of composites where the ply geometry is based on surfaces and contours. “Basic” composite validation properties at the part level are also in scope of this test case. The approximate explicit representation of composite plies, where there is a 3D tessellated solid for each ply, is out of scope for this test case.

The approach is to export and to import composite information in STEP AP242 based on the:

- AP242 Edition 2 IS Longform Express Schema, available on the CAX-IF homepage under “Public Testing Information”.
- The “AP242 Edition 1 MIM Longform EXPRESS Schema with Composite Patch” can be used as a fallback
- Recommended Practices for Composite Materials; Version 3.4; June 13, 2017
- Draft Recommended Practices for Composite Structure Validation Properties; Release 0.14; July 23, 2019

As the validation properties recommended practices have not been completely agreed upon, some tests will be done by end user checks.

2.5.3 Testing Instructions

The test case CPD_PUBLIC_LOTAR.CATPart will be used. The model has been provided by Airbus Helicopter.

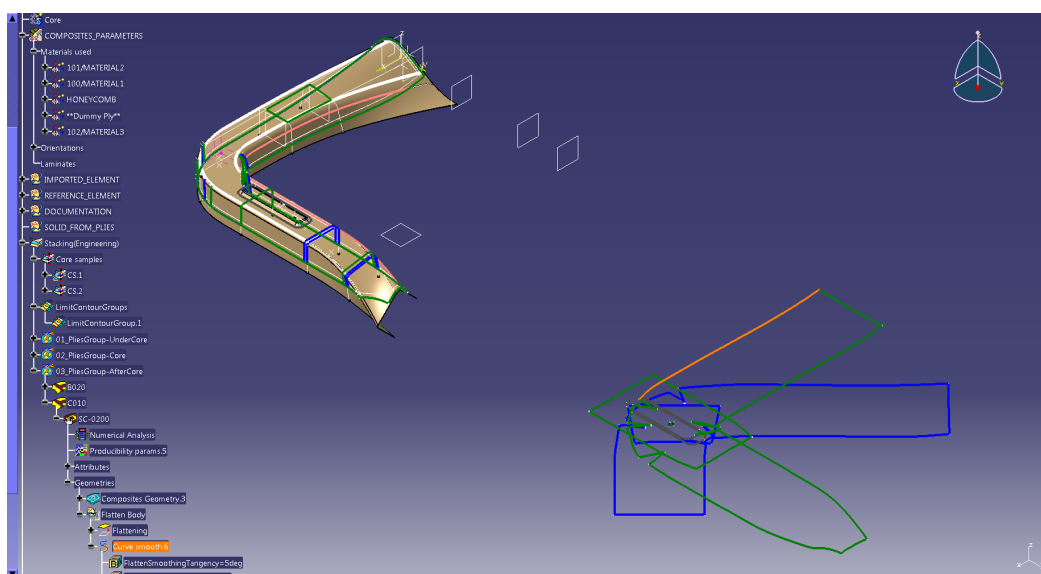

Figure 3: Illustration of the CO2 Test Case

The test case is available in the member area of the CAX-IF homepages, under “Information on Round 40J of Testing”.

2.5.4 Statistics

For each STEP file exported or imported for the CO2 test case, vendors must submit the corresponding statistics. To do so, go to the [CO2 Data Sheet], and either fill in the web form, or upload a comma-delimited file (.csv) with the data as listed below.

Native Statistics

When exporting a STEP file, report what data importing systems should expect to find. For numeric statistics, enter the respective value or 'na' if not supported. For other statistics, select either 'full support' (i.e. test case and Rec. Pracs. definitions are fulfilled), 'limited support' (meaning the implementation does not meet all criteria and issues may be expected on import), or 'na' if not supported.

Target Statistics

When importing a file, report the results found after processing the file as described below:

Ply-related Statistics

Several of the Statistics for this test case are related to a specific ply within a specific sequence (e.g., material, orientation, rosette). The statistics cannot evaluate this for all plies in the model. Hence, the idea is to select one specific (interesting) sequence and ply on export, and to publish its name in the "Composite Ply Sequence" field of the statistics. Then, fill in the other ply-related statistics with the values as valid for this particular sequence and ply. After import, select the sequence and ply with the name given in the native statistics, and again provide the values valid for this particular sequence and ply.

The sequence and ply to be used for evaluating the CO2 test case in Round 46J is:

PLY SC-0035 of SEQUENCE A035

Statistics for Core Sample Point

The position of the point for the Core Sample shall be given for:

CORE SAMPLE CS1

Statistics for Flatten Pattern

The length of the curve contour of the flatten pattern shall be given for:

PLY SC0200 of SEQUENCE C010

Data Sheet Columns

These statistics will be enhanced in future test rounds, especially with the release of newer versions of the Recommended Practices for Composite Structure Validation Properties.

column name	description
model	The name of the test model, here 'CO3'
system_n	The system code of the CAD system creating the STEP file
system_t	The system code of the CAD system importing the STEP file. For native stats, select 'stp'
unit	The unit the model is designed in
compos_tables	The number of Composite Tables in the Model
sequences	The number of Sequences in the model
plies	The total number of plies in the file
num_materials	Total number of Materials defined
compos_table_name	The name of the Composite Table of the model

column name	description
ply_sequence	The ID of the Sequence and the ID of the Ply within that Sequence for all ply-related statistics; e.g., "Ply.P4 of Sequence.S4".
seq_ply_number	The total number of Plies defined within the Sequence as listed in the "Composite Ply Sequence" column of the data sheet.
seq_ply_material	The name of the Material of the specific Ply and Sequence as listed in the "Composite Ply Sequence" column of the data sheet.
seq_ply_mat_type	The type of Material of the specific Ply and Sequence as listed in the "Composite Ply Sequence" column of the data sheet.
seq_ply_orient	pass/fail - whether the orientation of the specific Ply and Sequence as listed in the "Composite Ply Sequence" column of the data sheet was correct
seq_ply_rosette	The name of the Rosette of the specific Ply and Sequence as listed in the "Composite Ply Sequence" column of the data sheet.
ply_surface_area	The value of the area of the specific Ply and Sequence as listed in the "Composite Ply Sequence" column of the data sheet.
num_core_samples	The total number of core samples in the file
cs_pointx	Position of the point for the Core Sample indicated in the Test Suite.
cs_pointy	
cs_pointz	
fp_length	The length of the curve contour of the Flatten pattern of the ply and sequence indicated in the Test Suite document.
validation_c_tables	Total number of Composite Tables in the model, as received via the validation properties capability
validation_sequences	Total number of Sequences as received via the validation properties capability
validation_plies	Total number of Plies (entire assembly) as received via the validation properties capability
validation_c_materials	Total number of Materials as received via the validation properties capability
validation_c_orient	pass/fail, indicates whether the Number of Orientations per part in the model matches the Composite validation property value given in the STEP file
validation_ply_area	pass/fail, indicates whether the sum of all ply surface areas in the part matches the Composite validation property value given in the STEP file
validation_ply_centroid	pass/fail, indicates whether the sum of all ply geometric centroids in the part matches the Composite Validation Property value given in the STEP file
valid_cvp	pass/fail, is the instantiation of the validation properties for Tessellated Geometry in the STEP file as per the recommended practices?
date	The date when the statistics were last updated (will be filled in automatically)
issues	A short statement on issues with the file

2.6 Test Case CO3: Composite Materials (3D Explicit Ply Representation)

All information about this test case can also be viewed in CAESAR on its Information page.

2.6.1 Motivation

For several years, some STEP composite interfaces have been available in several CAD tools such as CATIA V5, FiberSIM and in CT CoreTechnologie tools, with a certain level of maturity proven by LOTAR pilot projects.

The goal of including Composite Materials in a CAX-IF test round is to align these implementations and provide an official framework for composite materials implementation tests as STEP AP 242e1 includes this capability.

2.6.2 Approach

The scope of this test case is the “3D tessellated” representation for each ply. The approximate explicit representation of composite plies includes a 3D tessellated solid for each ply.

The approach is to export and import the composite information in STEP AP242 based on the Recommended Practices for Composite Materials; Version 3.4; June 13, 2017. The document is available in the member area of the CAX-IF homepages, under “Information on Round 40J of Testing”.

Implementation requires at least using the “AP242 Edition 1 MIM Longform EXPRESS Schema with Composite Patch”, which is available in the same location.

The recommended schema to use, though, is the “AS242 Edition 2 IS Longform EXPRESS Schema”, which is available on the CAX-IF homepage under “Joint Testing Information”.

Refer to Annex C for further information on the extended data model.

As the validation properties recommended practices have not been completely agreed upon, the tests will be done by end user checks.

2.6.3 Testing Instructions

The test case ASME_Y14.37_RosetteType2.CATPart will be used. The model has been provided by The Boeing Company.

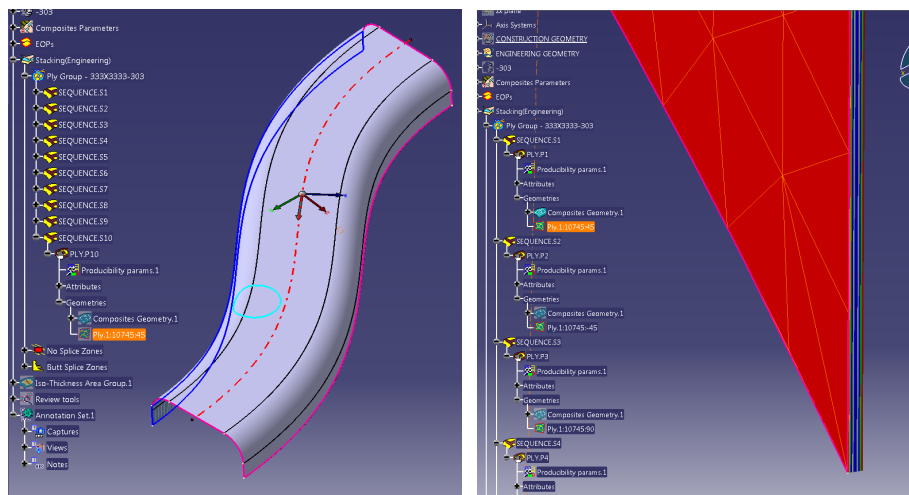

Figure 4: Illustration of the CO3 Test Case

The test model contains the 3D tessellated representation of each ply.

The test case is available in the member area of the CAX-IF homepages, under “Information on Round 40J of Testing”.

2.6.4 Statistics

For each STEP file exported or imported for the CO3 test case, vendors must submit the corresponding statistics. To do so, go to the [CO3 Data Sheet], and either fill in the web form, or upload a comma-delimited file (.csv) with the data as listed below.

Native Statistics

When exporting a STEP file, report what data importing systems should expect to find. For numeric statistics, enter the respective value or 'na' if not supported. For other statistics, select either 'full support' (i.e. test case and Rec. Pracs. definitions are fulfilled), 'limited support' (meaning the implementation does not meet all criteria and issues may be expected on import), or 'na' if not supported.

Target Statistics

When importing a STEP file, report the results found after processing the file as described in the table below.

Ply-related Statistics

Several of the Statistics for this test case are related to a specific ply within a specific sequence (e.g., material, orientation, rosette). The statistics cannot evaluate this for all plies in the model. Hence, the idea is to select one specific (interesting) sequence and ply on export, and to publish its name in the "Composite Ply Sequence" field of the statistics. Then, fill in the other ply-related statistics with the values as valid for this particular sequence and ply. After import, select the sequence and ply with the name given in the native statistics, and again provide the values valid for this particular sequence and ply.

The sequence and ply to be used for evaluating the CO3 test case in Round 46J is:

PLY.P4 of SEQUENCE S.4

Data Sheet Columns

column name	description
model	The name of the test model, here 'CO3'
system_n	The system code of the CAD system creating the STEP file
system_t	The system code of the CAD system importing the STEP file. For native stats, select 'stp'
unit	The unit the model is designed in
compos_tables	The number of Composite Tables in the Model
compos_table_name	The name of the Composite Table of the model
sequences	The number of Sequences in the model
plies	The total number of plies in the file
num_materials	Total number of Materials defined
num_saved_views	The number of Saved Views defined in the model
num_annotations	The total number of Annotations defined in the model.
ply_sequence	The ID of the Sequence and the ID of the Ply within that Sequence for all ply-related statistics. For CO3, use: "Ply.P4 of Sequence.S4".
seq_ply_number	The total number of Plies defined within the Sequence as listed in the "Composite Ply Sequence" column of the data sheet.

column name	description
seq_ply_material	The name of the Material of the specific Ply and Sequence as listed in the "Composite Ply Sequence" column of the data sheet.
seq_ply_mat_type	The type of Material of the specific Ply and Sequence as listed in the "Composite Ply Sequence" column of the data sheet.
seq_ply_orient	pass/fail - whether the orientation of the specific Ply and Sequence as listed in the "Composite Ply Sequence" column of the data sheet was correct
seq_ply_rosette	The name of the Rosette of the specific Ply and Sequence as listed in the "Composite Ply Sequence" column of the data sheet.
ply_rosette_type	The type of the Rosette of the specific Ply and Sequence as listed in the "Composite Ply Sequence" column of the data sheet.
ply_contour_area	The surface area of the ply contour of the specific Ply and Sequence as listed in the "Composite Ply Sequence" column of the data sheet.
facets	The number of facets in the Tessellated model
ply_explicit_area	The surface area of the 3D explicit representation (tessellated geometry) of the specific Ply and Sequence as listed in the "Composite Ply Sequence" column of the data sheet.
date	The date when the statistics were last updated (will be filled in automatically)
issues	A short statement on issues with the file

2.7 Test Case PID: Persistent IDs

All information about this test case can also be viewed in CAESAR on its Information page.

2.7.1 Motivation

The ability to track a product's model information during design iteration, and from design iteration through to manufacturing and quality analysis has been limited by the lack of support for persistent IDs in STEP.

With the inclusion of persistent IDs in STEP, collaborating systems should now be able to exchange model data and track that data during design iteration. This suggests the ability to retain IDs contained in external data from a sender and reference those entities by the receiver. When a change to that model data occurs on the sender's side, the receiver should be able to update the receiver's copy of that external data and have any dependent data in their own models that refer to that external change, and update to respond to the change.

As in the case of design iteration, the ability to track model entities via persistent IDs, will also allow downstream systems to update their representations of the design model and update their manufacturing and metrology planning to reflect changes in the design.

An additional benefit of the establishment of persistent IDs in STEP is the ability to retain a permanent audit trail of custody and connection between design and downstream systems for potential forensic analysis of critical product systems after in-service failure.

Finally, although not covered in this first test case, the introduction of persistent IDs provides the ability of any contributor to the information stream associated with a product's lifecycle to add information to the model that can be connected to existing model content and that additional information can be retrieved by subsequent users and used as feedback from the contributor.

2.7.2 Approach

The approach to be used is described in the “Recommended Practices for Permanent Entity IDs for Design Iteration and Downstream Exchange” (Version 0.5; 29 May 2020), which can be found in the CAx-IF member area under “Information on Round 46J of Testing”.

Within the domain of Persistent IDs, the following functionalities are in scope of Round 46J:

- Persistent IDs on Model (Product) for
 - testing the retention of model ID after changes in the underlying content
- Persistent IDs on Geometry for
 - testing the effect of a change in geometry and topology on dependent manufacturing planning that references that geometry and topology
 - testing the effect of a change in geometry and topology on dependent metrology planning that references that geometry and topology
 - this concept includes the introduction of Persistent IDs on Shape Aspect as they are used to collect individual geometry elements into logical groups for some downstream purposes
- Persistent IDs on Semantic PMI Representation for
 - testing the effect of changes in semantic PMI on dependent manufacturing planning that reference that semantic PMI
 - testing the effect of changes in semantic PMI on dependent metrology planning that reference that semantic PMI
- Persistent IDs on UDAs for
 - testing the effect of changes in UDAs attached to model, semantic PMI, or geometry on dependent manufacturing or metrology planning that reference that those UDAs

The following are out of scope for Round 46J and are moved to the Future Considerations section:

- Persistent IDs on Geometry and Persistent IDs on Semantic PMI Representation for
 - testing assembly constraints referencing those geometries
 - testing the effect of change in geometry and topology on dependent shape that references that geometry and topology for design iteration

The preferred AP242 schema to be used is the AP242 Edition 2 IS schema, which can be found on the public CAx-IF web sites under “Public Testing Information”. As a fallback, the AP242 Edition 1 IS version can be used.

2.7.3 Testing Instructions

The tests will be performed based on an existing NIST test model, well known to the CAx-IF community, namely the NIST PMI test case FTC-09.

2.7.3.1 Test Model Overview

The specific test model to be used in this test case is a modified version of the NIST FTC-09 test case for testing persistent IDs and the effect of model change on downstream manufacturing and metrology planning.

2.7.3.2 Test Model Access

The native CAD files can be downloaded from the NIST homepage. See section 2.1.3.2 for details and direct download links.

2.7.3.3 Test Model Configuration

Unlike any previous CAX-IF test round, the PID test case requires iteration to confirm retention of persistent entity IDs. This iteration process implies a minimum of two exchanges – an initial exchange and a subsequent exchange. Test cases for downstream uses variants of the NIST Test Case FTC-09 (see Annex B). The two iterations will be identified by model suffixes in CAESAR (PID_1 – Initial Exchange; PID_2 – Subsequent Exchange).

Note also that there are two mechanisms for supporting the introduction of persistent IDs to STEP. The first is via the creation of new persistent `id_attribute` entities attached to certain entities within the Data Section of the Part 21 file. The second is via the creation of persistent ID relationships between STEP entity IDs and persistent entity IDs within an Anchor Section of a Part 21 Edition 3 file. Please refer to the recommended practice document for further details about the valid entity types to be used with `id_attribute` entities in the Data Section. Based on agreement, the scope of Round 46J will include only the first type of ID, i.e. `id_attribute` in the Data Section. This is reflected in the current version of the Recommended Practices. The testing of the Anchor Section approach will be considered in a future test round.

Test Case PID – Persistent Identifiers, via Data Section

The FTC-09 NIST model will be used, however we need to supplement the test case with additional information as follows.

Please add the following User Defined Attributes (UDAs):

- Attributes (UDAs) at the Product level in your native CAD model (taken from ASME 14.47, DRAFT, Feb 2018, Table 6-3 Metadata Elements (partial))

Element Name	Data Type	Description
CREATE_DATE	ISO 8601 extended form date/time	Date the data set was initially created.
MODEL_UNITS	String	System of units of measure (SI or U.S. Customary) of the model.
NOMENCLATURE	String	“NIST FTC09 Modified”
MODEL_PRECISION	Integer	Value that indicates numeric accuracy (number of significant digits) of model required in production of part in order for it to fulfill the design intent (ASME Y14.41).
REV	String	Current revision of the design per ASME Y14.35.

- Attributes (UDAs) on PMI (some PMI, not all):
 - UDA Name – “Severity Description”
 - UDA Type – String

- UDA Value – “Critical”
- UDA Name – “Severity Value”
- UDA Type – Integer
- UDA Value – 2

Please add the following Features (Shape Aspects):

- Collection of Geometries (surfaces) for the slotted hole (see Figure 5 below)

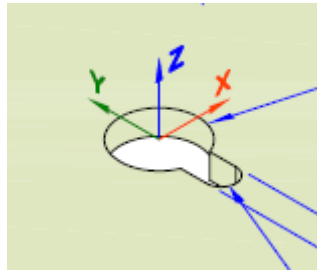

Figure 5: NIST FTC09, View C, slotted hole

Preprocessor (CAD)

Initial Iteration (PID_1)

- Export FTC09 as modified above (including IDs on Product, Geometry, Shape Aspect, PMI, and UDA)

Second Iteration (PID_2)

Modify UDAs as follows:

- UDA Name – “REV”
- UDA Type – Real or Integer (see below)
- UDA Value – if the model contains a PLM version attribute, use that type and value; if not, use the integer type with value 2

Modify the hole geometry and tolerance info for the 3 instances of the hole shown in Figure 6:

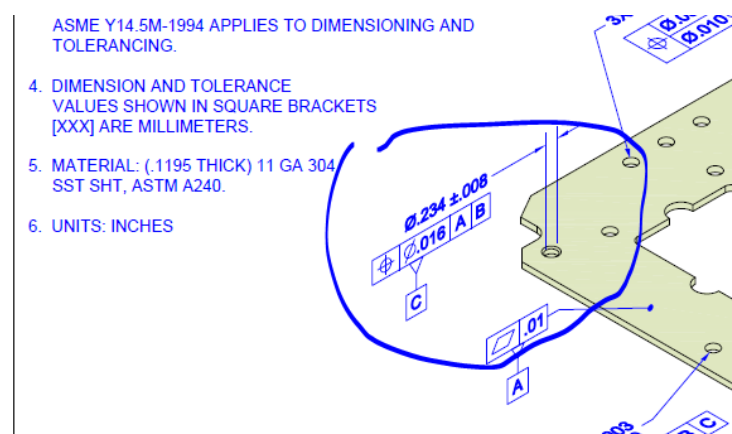

Figure 6: NIST Test Case FTC09, View A, Detail of Hole

- Change the three instances of 0.016 location tolerances to 0.014; add Criticality UDA on these two tolerances.
- Change the three nominal hole diameters from 0.234 to 0.236 and hole diameter tolerance values from 0.008 to 0.010

Slotted Hole (see Figure 7):

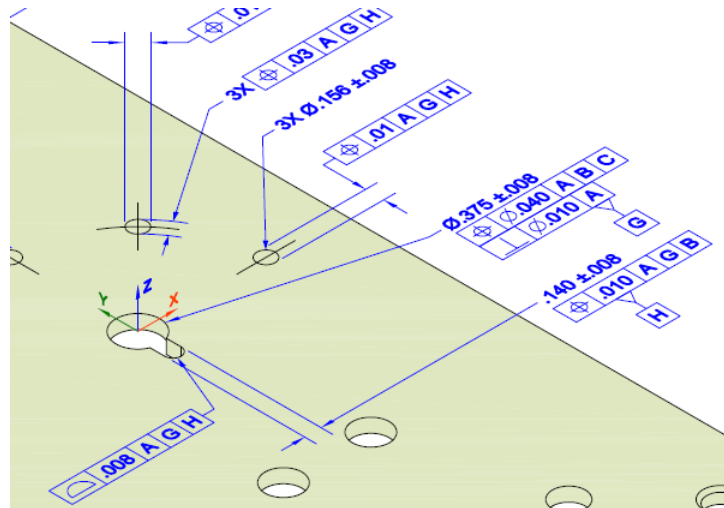

Figure 7: NIST Test Case FTC09, View C, Detail of Slotted Hole

- Change the hole diameter from 0.375 to 0.385, and
- Change the slot width from 0.140 to 0.150.

Postprocessor (CAD System or Manufacturing and/or Metrology Planning System)

Initial Iteration (PID_1)

- Import FTC09 and confirm receipt of Persistent IDs on Product, on Geometry, on Shape Aspect, on PMI, and on UDAs

Second Iteration (PID_2)

Import revised FTC09 and confirm receipt of the same Persistent IDs on Product, on Geometry, on Shape Aspect, on PMI, and on UDAs as were received in PID1:

- Confirm change to location tolerance values
- Confirm retention of Criticality UDA on these tolerances
- Confirm change to hole diameters (geometry and nominal value) and hole diameter tolerance values; confirm aggregate and individual IDs on hole cylinders and their shape aspect
- Confirm change to slot geometry; Confirm aggregate and individual IDs on reference surfaces and their shape aspect

2.7.4 Statistics

For each STEP file exported or imported for during one of the iterations of the PID test case, vendors must submit the corresponding statistics. To do so, go to the [PID Data Sheet], and either fill in the web form, or upload a comma-delimited file (.csv) with the data as listed below.

Native Statistics

When exporting a STEP file, report what data importing systems should expect to find. For numeric statistics, enter the respective value or 'na' if not supported. For other statistics, select either 'full support' (i.e. test case and Rec. Pracs. definitions are fulfilled), 'limited support' (meaning the implementation does not meet all criteria and issues may be expected on import), or 'na' if not supported.

Target Statistics

When importing a STEP file, report the results found after processing the file as described below.

Data Sheet Columns

column name	description
model	The name of the test model, here 'PID'. Important: Add the iteration as suffix to the model, i.e.: <ul style="list-style-type: none"> • PID_1 for the initial exchange • PID_2 for the subsequent exchange
system_n	The system code of the CAD system creating the STEP file
system_t	The system code of the CAD system importing the STEP file. For native stats, select 'stp'
pid_product	pass/fail – whether the persistent ID at the product level was transferred correctly
num_pid_pmi	The number of semantic PMI elements processed with persistent IDs
num_pid_topol	The number of topological elements (e.g., <code>advanced_face</code>) processed with persistent IDs
num_pid_shape	The number of <code>shape_aspects</code> processed with persistent IDs
num_pid_uda	The number of user defined attributes processed with persistent IDs
downstream_update	all/partial/none - indicates whether the receiving system was able to successfully update the references on subsequent iterations
date	The date when the statistics were last updated (will be filled in automatically)
issues	A short statement on issues with the file

Annex A NIST Model Translation Configuration Considerations

Based on data translation issues identified in the NIST Phase 2 project (requiring multiple dataset submission iterations to resolve), the following translator configuration considerations have been derived for the PMI-related test cases (SP7 and TGP3) in Round 46J:

- Include annotations, coordinate systems, model properties, and PMI views
- Include supplemental geometry (non-solid surfaces, curves, points)
- Preserve annotation associations with both product and supplemental geometry
- Preserve annotation semantic PMI properties
 - Clearly point out if these are intentionally not translated
- Preserve annotation text
 - Creo should be configured to display dimension tolerances (tol_display on)
 - Do not drop leading zeros or add trailing zeros
- Preserve annotation units
 - CTC 01, 02, and 04 are defined in millimeters
 - CTC 03 and 05 are defined in inches
 - FTC 06 through 09 models are defined in inches
 - FTC 10 and 11 models are defined in millimeters
- Preserve display names of annotations and coordinate systems
 - Point out if you use NX 9 or newer since this will change some of the annotation names (see Figure 8 below)
- Preserve display colors of product geometry, supplemental geometry, and annotations
- Preserve view-specific visibility of annotations, coordinate systems, and supplemental geometry:
 - In the ZIP files with the test case specifications (see links in section 2.1.3), there is a PDF named "*nist_[ctc/ftc]_suppl_elem_visibility.pdf*" which gives a detailed definition of which elements shall be visible in which view, and which not.
 - Note that for each test case, there is a second PDF document included in the ZIP files, named "*..._elem_ids.pdf*" which contains the element ids for unambiguous identification of all PMI.
- Preserve view frustum (orientation and zoom level) definition:
 - JT model views should be defined so they are listed in the "Model Views" menu of JT2Go and work properly when selected
- Do not export extraneous information
 - Only CATIA Captures (not Views) should be exported to STEP Saved Views
 - Creo sketch dimensions should only be included when visible in a Combined View

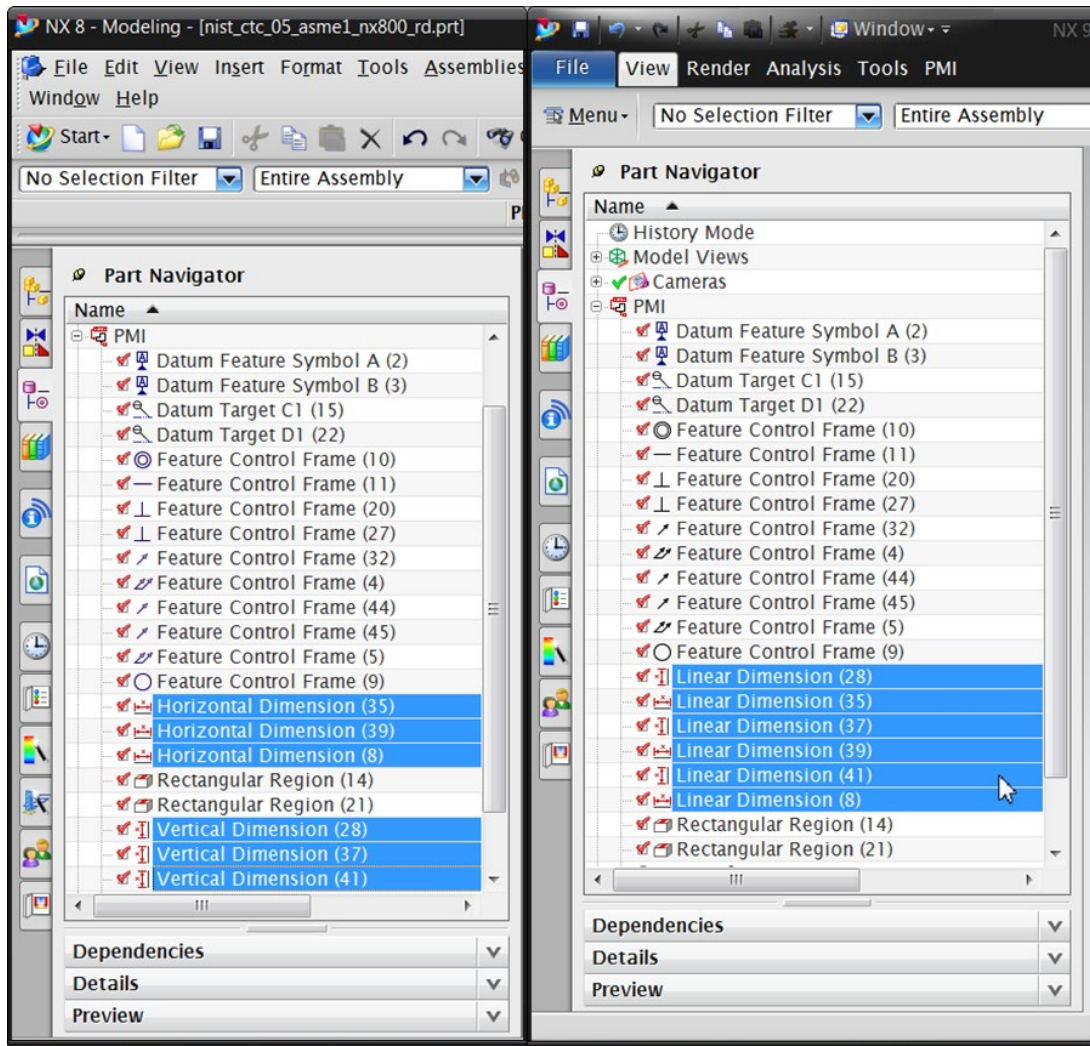

Figure 8: NX 8 vs. NX 9 Dimension Display Names

Annex B NIST Model Definitions

This section provides an overview of the test models used for testing of PMI capabilities in Round 46J, namely SP7 (see section 2.1) and TGP3 (see section 2.2). All of these models have been developed in the course of NIST's "MBE PMI Validation and Conformance Testing Project". Information on this project and related activities can be found on internet at <https://pages.nist.gov/CAD-PMI-Testing/>

The full suite of models consists of two data sets:

First, the so-called Complex Text Cases (CTC). These are the models with indices 01-05. They contain a collection of basic PMI constructs. Download the definitions from:

https://s3.amazonaws.com/nist-el/mfg_digitalthread/NIST_CTC_Definitions_Dec_2016.zip

Second, the so-called Fully-toleranced Test Cases (FTC). These are the models with indices 06-11. They are fully defined models, providing all information required to actually manufacture and inspect the models. Download the definitions from:

https://s3.amazonaws.com/nist-el/mfg_digitalthread/NIST_FTC_Definitions_Dec_2016.zip

In order to reduce the workload for the participating vendors, not all eleven models shall be tested in Round 46J. The following five models have chosen:

- SP7: CTC 2, 3 & 5; FTC 6 & 8
- TGP3: CTC 2, 3 & 5; FTC 6 & 8

This selection still covers a wide range of PMI elements, while reducing the number of exchanged to be done for each interface vendor. The models are indicated with a label below.

The illustrations below show the first page of the PDF document for each test model.

NIST PMI Test Models - 2012

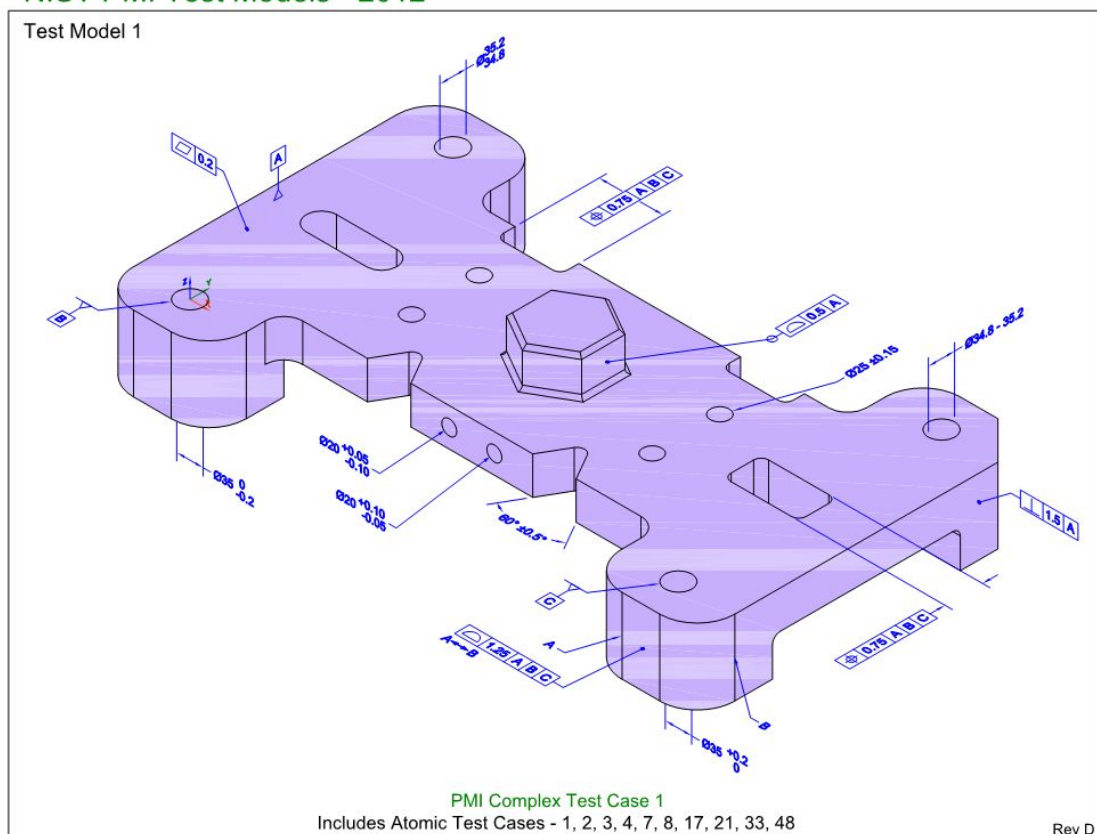

NIST PMI Test Models - 2012

Test Model 2

R46J

NOTES (UNLESS OTHERWISE SPECIFIED):

- OBTAIN DIMENSIONS FOR ALL UNDIMENSIONED FEATURES FROM THE MODEL. ALL DIMENSIONS OBTAINED FROM THE MODEL ARE BASIC UNLESS OTHERWISE SPECIFIED.
- ASME Y14.41-2003 APPLIES TO DATASET.
- ASME Y14.5M-1994 APPLIES TO DIMENSIONING AND TOLERANCING.

These notes shall be placed on a static annotation plane (the plane does not rotate with the model).

The intent of ATC50 is to test systems' support for static annotation planes.

Including a feature control frame in a general note will be a test case in the next round of testing.

PMI Complex Test Case 2 - View 1 (of 3)
 Includes Atomic Test Cases - 28, 29, 43, 47, 50

Rev C

nist_ctc_02_asme1_rc

NIST PMI Test Models - 2012

Test Model 3

R46J

PMI Complex Test Case 3
 Includes Atomic Test Cases - 6, 13, 14, 20, 27, 32, 36, 39, 45, 46

Rev C

nist_ctc_03_asme1_rc

NIST PMI Test Models - 2014

NOTES (UNLESS OTHERWISE SPECIFIED):

- CAD MODEL _____ REV. ____ IS REQUIRED TO COMPLETE PRODUCT DEFINITION.
- DIRECTLY-TOLERANCED DIMENSIONS AND BASIC DIMENSIONS DEFINED ON THE DRAWING TAKE PRECEDENCE OVER DIMENSIONAL DATA DEFINED BY THE MODEL. OBTAIN ALL OTHER DIMENSIONAL DATA FROM THE MODEL. THE MODEL REPRESENTS BASIC DIMENSIONAL DATA UNLESS OTHERWISE SPECIFIED.
- APPLICABLE STANDARDS:
 ASME Y14.41-2003 APPLIES TO DATASET.
 ASME Y14.5M-1994 APPLIES TO DIMENSIONING AND TOLERANCING.
- $\text{[Symbol: Flatness]} \text{[Tolerance: .05]} \text{[Feature: A|B|C]}$ APPLIES TO ALL UNTOLERANCED SURFACES.
- UNITS: INCHES

Feature and Specification Index

R46J

PMI Fully-Toleranced Test Case 6 - View A
 Includes Atomic Test Cases - 52, 53, 72, 87, 88, 89

Rev D nist_ftc_06_asme1_rd

NIST PMI Test Models - 2014

NOTES (UNLESS OTHERWISE SPECIFIED):

- CAD MODEL _____ REV. ____ IS REQUIRED TO COMPLETE PRODUCT DEFINITION.
- DIRECTLY-TOLERANCED DIMENSIONS AND BASIC DIMENSIONS DEFINED ON THE DRAWING TAKE PRECEDENCE OVER DIMENSIONAL DATA DEFINED BY THE MODEL. OBTAIN ALL OTHER DIMENSIONAL DATA FROM THE MODEL. THE MODEL REPRESENTS BASIC DIMENSIONAL DATA UNLESS OTHERWISE SPECIFIED.
- APPLICABLE STANDARDS:
 ASME Y14.41-2003 APPLIES TO DATASET.
 ASME Y14.5M-1994 APPLIES TO DIMENSIONING AND TOLERANCING.
- $\text{[Symbol: Flatness]} \text{[Tolerance: .06]} \text{[Feature: A|B|C]}$ APPLIES TO ALL UNTOLERANCED SURFACES.
- FEATURES IDENTIFIED AS STATISTICALLY TOLERANCED (ST) SHALL BE PRODUCED WITH STATISTICAL PROCESS CONTROLS OR TO THE MORE RESTRICTIVE ARITHMETIC LIMITS SPECIFIED. DETAILED PROCESS PLAN NEEDED TO COMPLETELY DEFINE STATISTICAL PARAMETERS AND REQUIREMENTS.
- UNITS: INCHES

Feature and Specification Index

nist_ftc_07_asme1_rd_fsi.pdf

PMI Fully-Toleranced Test Case 7 - View A
 Includes Atomic Test Cases - 84, 85

Rev D nist_ftc_07_asme1_rd

NIST PMI Test Models - 2014

NOTES (UNLESS OTHERWISE SPECIFIED):

- CAD MODEL _____ REV. ____ IS REQUIRED TO COMPLETE PRODUCT DEFINITION.
- DIRECTLY-TOLERANCED DIMENSIONS AND BASIC DIMENSIONS DEFINED ON THE DRAWING TAKE PRECEDENCE OVER DIMENSIONAL DATA DEFINED BY THE MODEL. OBTAIN ALL OTHER DIMENSIONAL DATA FROM THE MODEL. THE MODEL REPRESENTS BASIC DIMENSIONAL DATA UNLESS OTHERWISE SPECIFIED.
- APPLICABLE STANDARDS:
 ASME Y14.41-2003 APPLIES TO DATASET.
 ASME Y14.5M-1994 APPLIES TO DIMENSIONING AND TOLERANCING.
- $\square .06 \square A \square B \square C$ APPLIES TO ALL UNTOLERANCED SURFACES.
- DIMENSIONING AND TOLERANCING APPLY WITH PART RESTRAINED AS FOLLOWS, EXCEPT AS INDICATED.
 PLACE DATUM FEATURE A AGAINST DATUM FEATURE SIMULATOR A.
 ENGAGE DATUM FEATURES B AND C WITH DATUM FEATURE SIMULATORS B AND C RESPECTIVELY.
 APPLY LOAD TO PART TO RESTRAIN DATUM FEATURE A AGAINST ITS SIMULATOR.
 DETAILED INSPECTION PLAN NEEDED TO COMPLETELY DEFINE RESTRAINT.
- UNITS: INCHES

Feature and Specification Index

R46J

PMI Fully-Toleranced Test Case 8 - View A
 Includes Atomic Test Cases - 66, 90

Rev C

nist_ftc_08_asme1_rc

NIST PMI Test Models - 2014

NOTES (UNLESS OTHERWISE SPECIFIED):

- CAD MODEL _____ REV. ____ IS REQUIRED TO COMPLETE PRODUCT DEFINITION.
- DIRECTLY-TOLERANCED DIMENSIONS AND BASIC DIMENSIONS DEFINED ON THE DRAWING TAKE PRECEDENCE OVER DIMENSIONAL DATA DEFINED BY THE MODEL. OBTAIN ALL OTHER DIMENSIONAL DATA FROM THE MODEL. THE MODEL REPRESENTS BASIC DIMENSIONAL DATA UNLESS OTHERWISE SPECIFIED.
- APPLICABLE STANDARDS:
 ASME Y14.41-2003 APPLIES TO DATASET.
 ASME Y14.5M-1994 APPLIES TO DIMENSIONING AND TOLERANCING.
- DIMENSION AND TOLERANCE VALUES SHOWN IN SQUARE BRACKETS [XXX] ARE MILLIMETERS.
- MATERIAL: (.1195 THICK) 11 GA 304 SST SHT, ASTM A240.
- UNITS: INCHES

Feature and Specification Index

nist_ftc_09_asme1_rd_fsi.pdf

PMI Fully-Toleranced Test Case 9 - View A
 Includes Atomic Test Cases - 59, 61

Rev D

nist_ftc_09_asme1_rd

NIST PMI Test Models - 2014

NOTES (UNLESS OTHERWISE SPECIFIED):

- CAD MODEL _____ REV. ___ IS REQUIRED TO COMPLETE PRODUCT DEFINITION.
- DIRECTLY-TOLERANCED DIMENSIONS AND BASIC DIMENSIONS DEFINED ON THE DRAWING TAKE PRECEDENCE OVER DIMENSIONAL DATA DEFINED BY THE MODEL. OBTAIN ALL OTHER DIMENSIONAL DATA FROM THE MODEL. THE MODEL REPRESENTS BASIC DIMENSIONAL DATA UNLESS OTHERWISE SPECIFIED.
- APPLICABLE STANDARDS:
 ASME Y14.41-2003 APPLIES TO DATASET AND MOVABLE DATUM TARGETS.

 ASME Y14.5M-1994 APPLIES TO DIMENSIONING AND TOLERANCING.
- FULL DIAMETER OF EACH INDICATED HOLE MUST INTERSECT WITH THE CROSS-DRILLED HOLE AT ITS BOTTOM. INDICATED HOLES MUST NOT CONTACT FAR SIDE OF CROSS-DRILLED HOLES.
- $\text{1.5} \text{ A B C}$ APPLIES TO ALL UNTOLERANCED SURFACES.
- UNITS: MILLIMETERS

Feature and Specification Index
 nist_ftc_10_asme1_rb_fsi.pdf

PMI Fully-Toleranced Test Case 10 - View A
 Includes Atomic Test Cases - N/A

Rev B

nist_ftc_10_asme1_rb

NIST PMI Test Models - 2014

NOTES (UNLESS OTHERWISE SPECIFIED):

- CAD MODEL _____ REV. ___ IS REQUIRED TO COMPLETE PRODUCT DEFINITION.
- DIRECTLY-TOLERANCED DIMENSIONS AND BASIC DIMENSIONS DEFINED ON THE DRAWING TAKE PRECEDENCE OVER DIMENSIONAL DATA DEFINED BY THE MODEL. OBTAIN ALL OTHER DIMENSIONAL DATA FROM THE MODEL. THE MODEL REPRESENTS BASIC DIMENSIONAL DATA UNLESS OTHERWISE SPECIFIED.
- APPLICABLE STANDARDS:
 ASME Y14.41-2003 APPLIES TO DATASET.

 ASME Y14.5M-1994 APPLIES TO DIMENSIONING AND TOLERANCING.
- NON-RIGID PART. DIRECTLY-TOLERANCED DIMENSIONS AND TOLERANCES APPLY IN FREE STATE.
- UNITS: MILLIMETERS

Feature and Specification Index
 nist_ftc_11_asme1_rb_fsi.pdf

PMI Fully-Toleranced Test Case 11 - View A
 Includes Atomic Test Cases - 55, 100

Rev B

nist_ftc_11_asme1_rb

Annex C Composite Data model for Rosette Type 2

This section gives some additional information provided by Dassault Systèmes on the CO3 test case, see section 2.6.

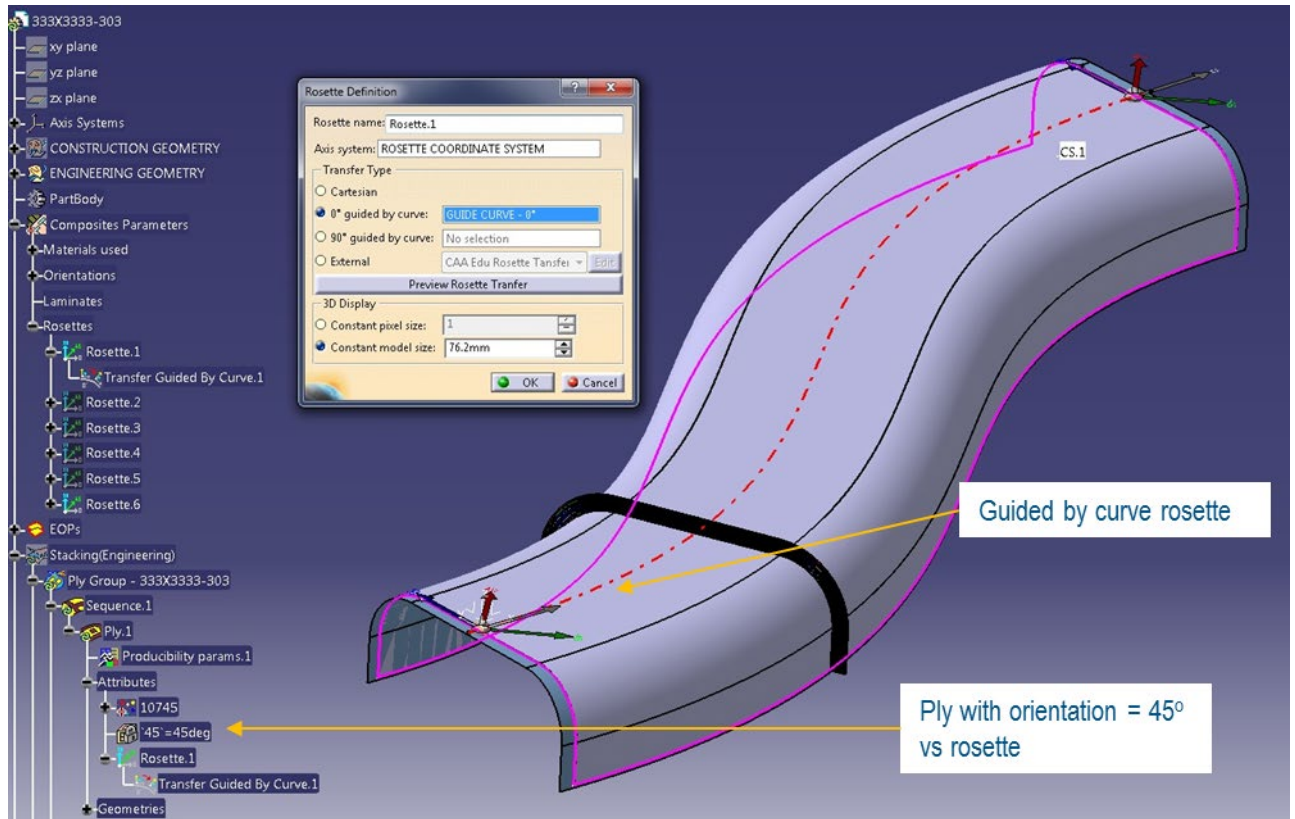

Figure 9: ASME_Y14.37_RosetteType2.CATPart

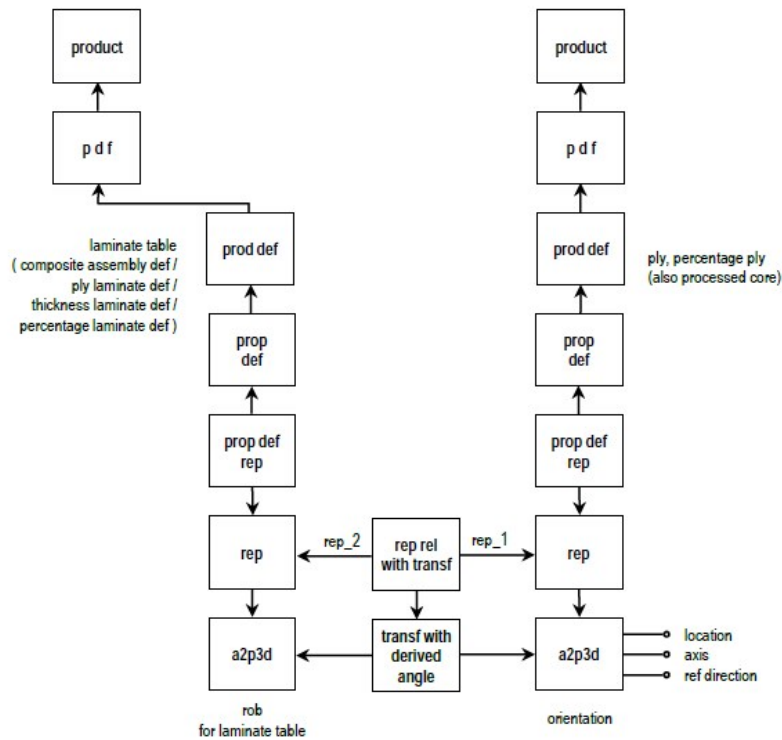

Figure 15: Ply Orientation by Simple Rosette

Figure 10: Old Recommendation from AP203e2

In AP203 Edition, the 2nd axis2_placement_3d provided the orientation angle (same axis, angle between ref_directions (= x-axis)) as shown in Figure 10 above. However, this only works for cartesian rosette.

In AP242e2, the orientation angle is explicitly defined, as shown in Figure 11 below. This works for cartesian, curve guided, cylindrical, polar etc. rosettes.

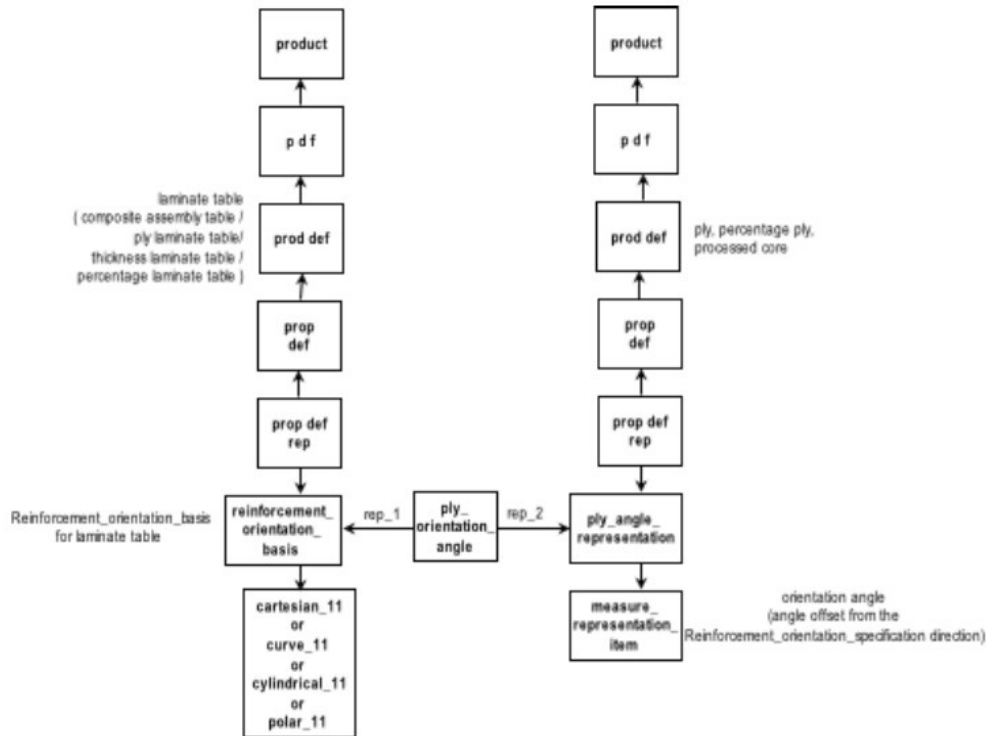

Figure 15: Ply Orientation Angle by Cartesian Placement, Curve, Cylindrical, or Polar 11 Basis Direction

Figure 11: New Recommendations AP242 E2

The new entities developed to support this are described below. They are contained in the “AP242 Edition 1 MIM Longform EXPRESS Schema with Composite Patch”, which is available in the CAX-IF member area under “Information on Round 40J of Testing”.

```

ENTITY reinforcement_orientation_basis
  SUBTYPE OF (representation);
  SELF\representation.items : SET[1:1] OF basis_11_direction_member;
END_ENTITY;

TYPE basis_11_direction_member = SELECT
  (cartesian_11,
  curve_11);
END_TYPE;

ENTITY cartesian_11
  SUBTYPE OF (geometric_representation_item);
END_ENTITY;
    
```



```
ENTITY cartesian_11
  SUBTYPE OF (geometric_representation_item);
END_ENTITY;

ENTITY curve_11
  SUBTYPE OF (geometric_representation_item);
END_ENTITY;

ENTITY ply_angle_representation
  SUBTYPE OF (representation);
  self\representation.items : SET [1:1] OF measure_representation_item;
END_ENTITY;

ENTITY ply_orientation_angle
  SUBTYPE OF (representation_relationship);
  SELF\representation_relationship.rep_1 : reinforcement_orientation_basis;
  SELF\representation_relationship.rep_2 : ply_angle_representation;
END_ENTITY;

ENTITY draped_orientation_angle
  SUBTYPE OF (ply_orientation_angle);
END_ENTITY;

ENTITY laid_orientation_angle
  SUBTYPE OF (ply_orientation_angle);
END_ENTITY;
```